



Real-Time Systems (0630581)

Lecture (2)

Classification of Real-Time Systems

Prof. Kasim M. Al-Aubidy
Computer Engineering Department
Philadelphia University

Lecture Outline:

- Historical background.
- Elements of a real-time system.
- What is a real-time system?
- Classification of real-time systems.
- Characteristics of a real-time system.

Historical Background:

- Brown and Campbell (1950) : (in paper only)
- Using a computer operating in real-time as part of a control system . (analog computing elements)
- The 1st digital computers developed specifically for R.T.S. were for airborne operating. in 1954 a digital computer was successfully used to provide an automatic flight and weapons control system .
- The 1st industrial installation of a computer system was in September, 1958 for plant monitoring at power station in sterling , Louisiana .
- The 1st industrial computer control installation was mad by the Texaco company who installed an RW-300 system at their port Arthur refinery in Texas on 15/03/1959
- The 1st DDC computer system was the Ferranti Argus 200 system installed in November, 1962 at the ICI, Lancashire, UK. It has 120 control loops and 256 measurements .
- The advent of the Microprocessor in 1974 made economically possible the use of DDC and distributed computer control systems.

Real-Time Systems

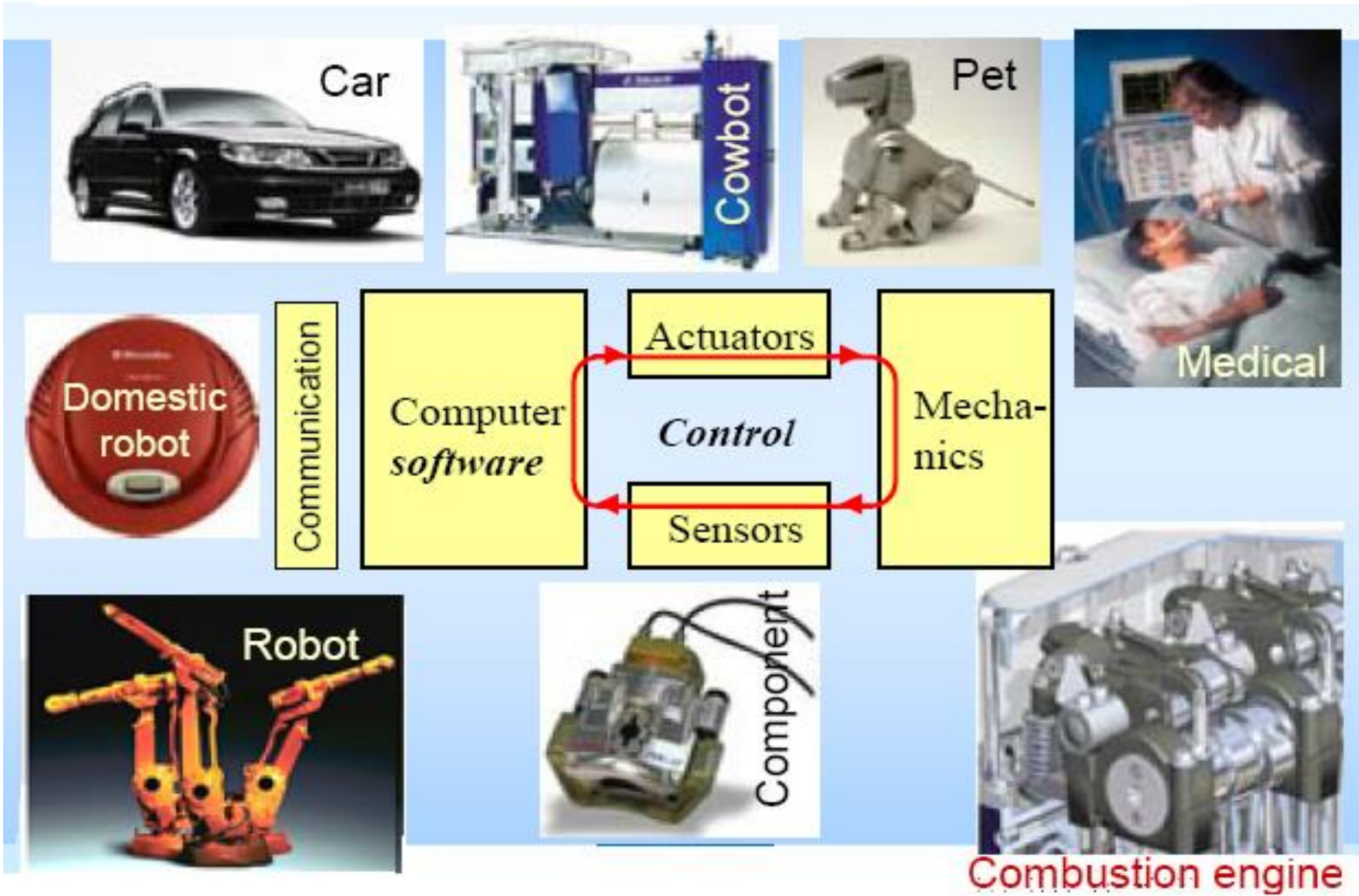

Elements of a Real-Time System:

A simple plant – a hot-air blower.

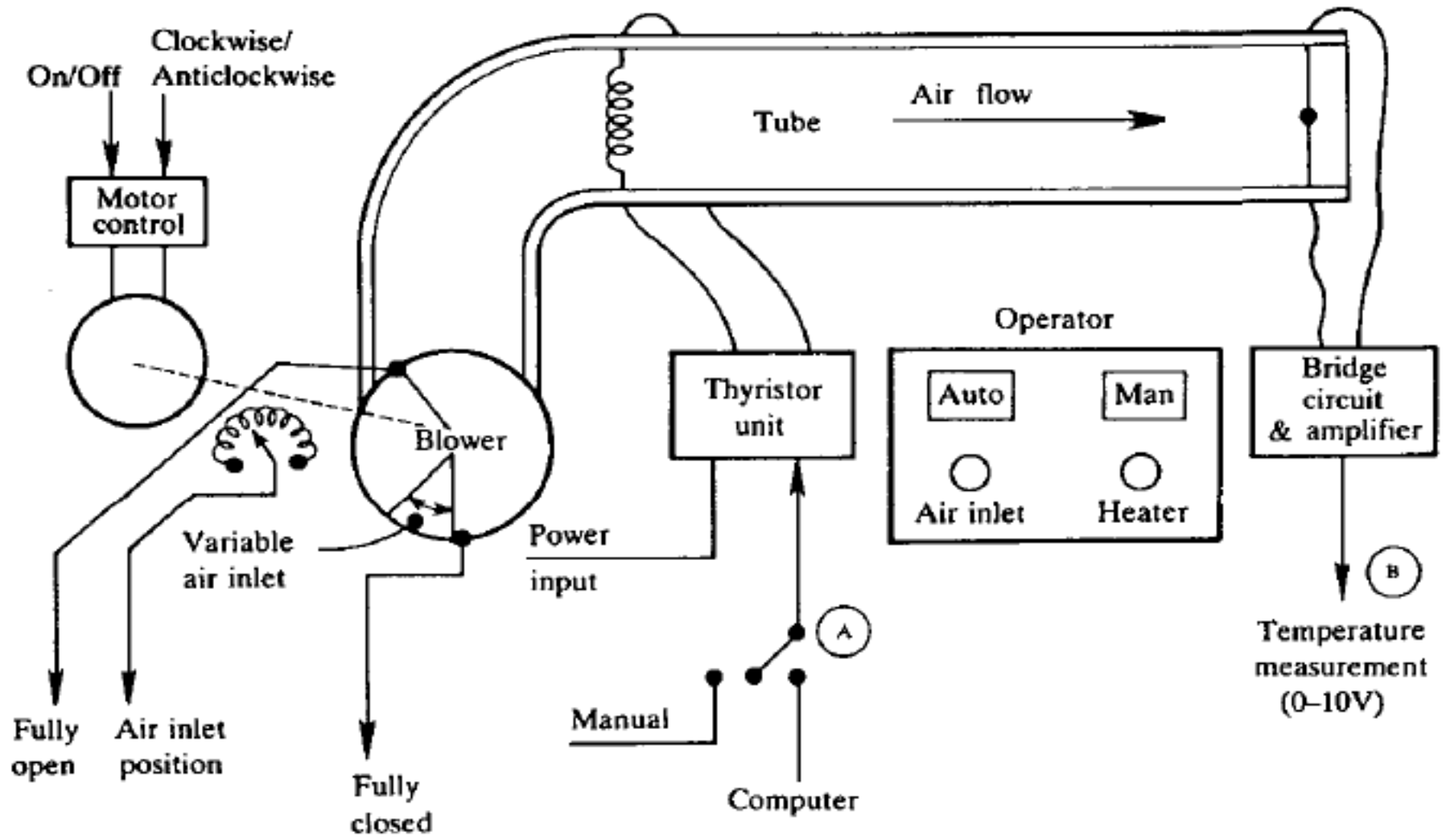

Elements of a Computer Control System:

- A centrifugal fan blows air over a heating element and into a tube.
- A thermostat is used to detect the temp.
- The position of the air-inlet cover to the fan is adjusted by a reversible DC motor (constant speed).
- A potentiometer is attached to the air-inlet cover .
- Two 8-switches are used to detect when the cover is fully open or fully closed .
- The operator is provided with a panel from which the control system can be switched from automatic to manual control panel. Lights indicate: Fan ON, Heater ON, Cover fully-open, Cover fully-closed, Auto/Manual status.
- The information is available from the plant instrument in the following two forms:
 - Analog signals : Air Temp., Fan-inlet cover position .
 - Digital signals : Fan-inlet cover position (Fully-open, Fully-closed)
 - Status signals : Auto/Manual , Fan motor ON, Heater ON

Computer Control Of a Hot-air Blower :

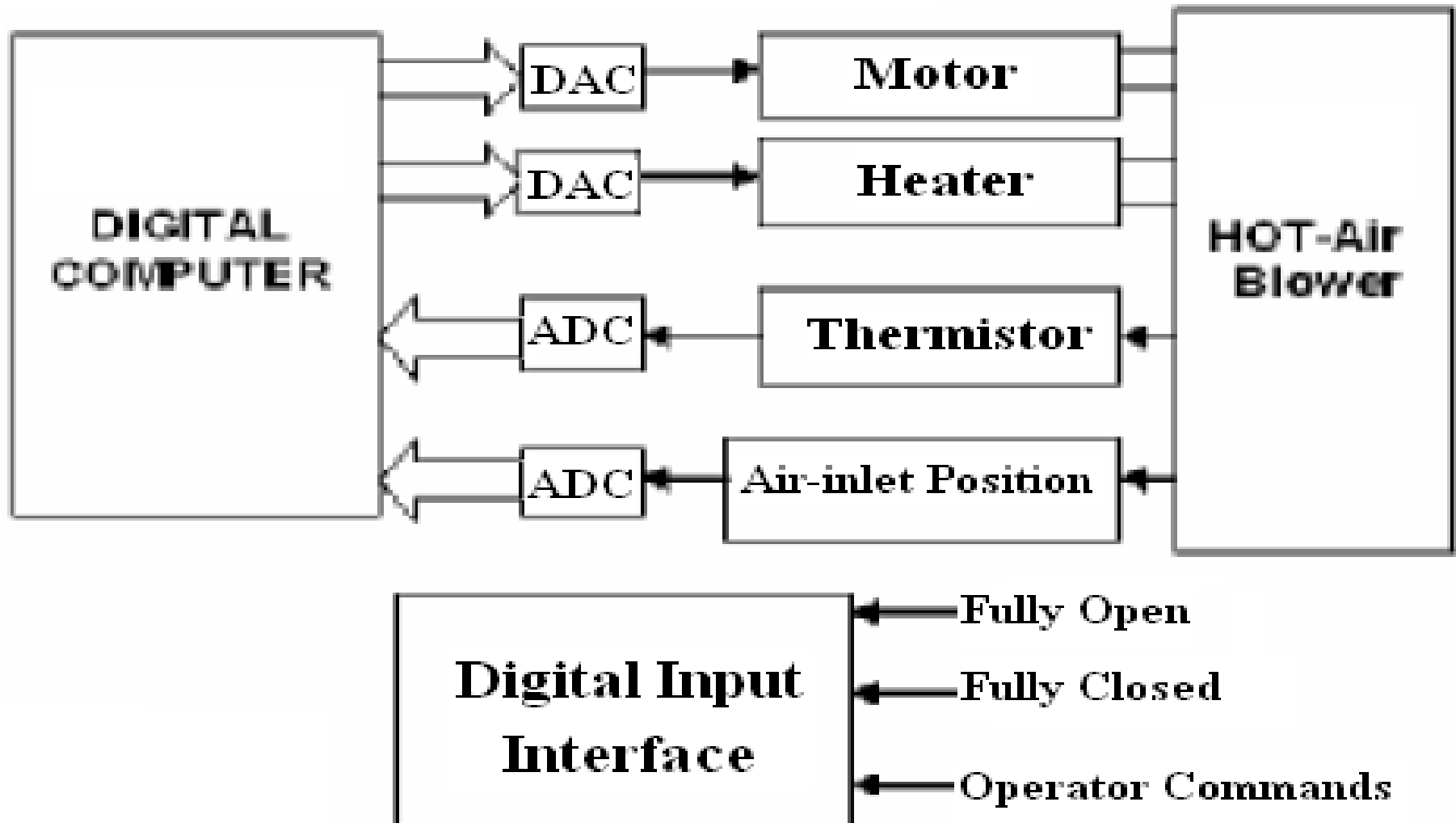

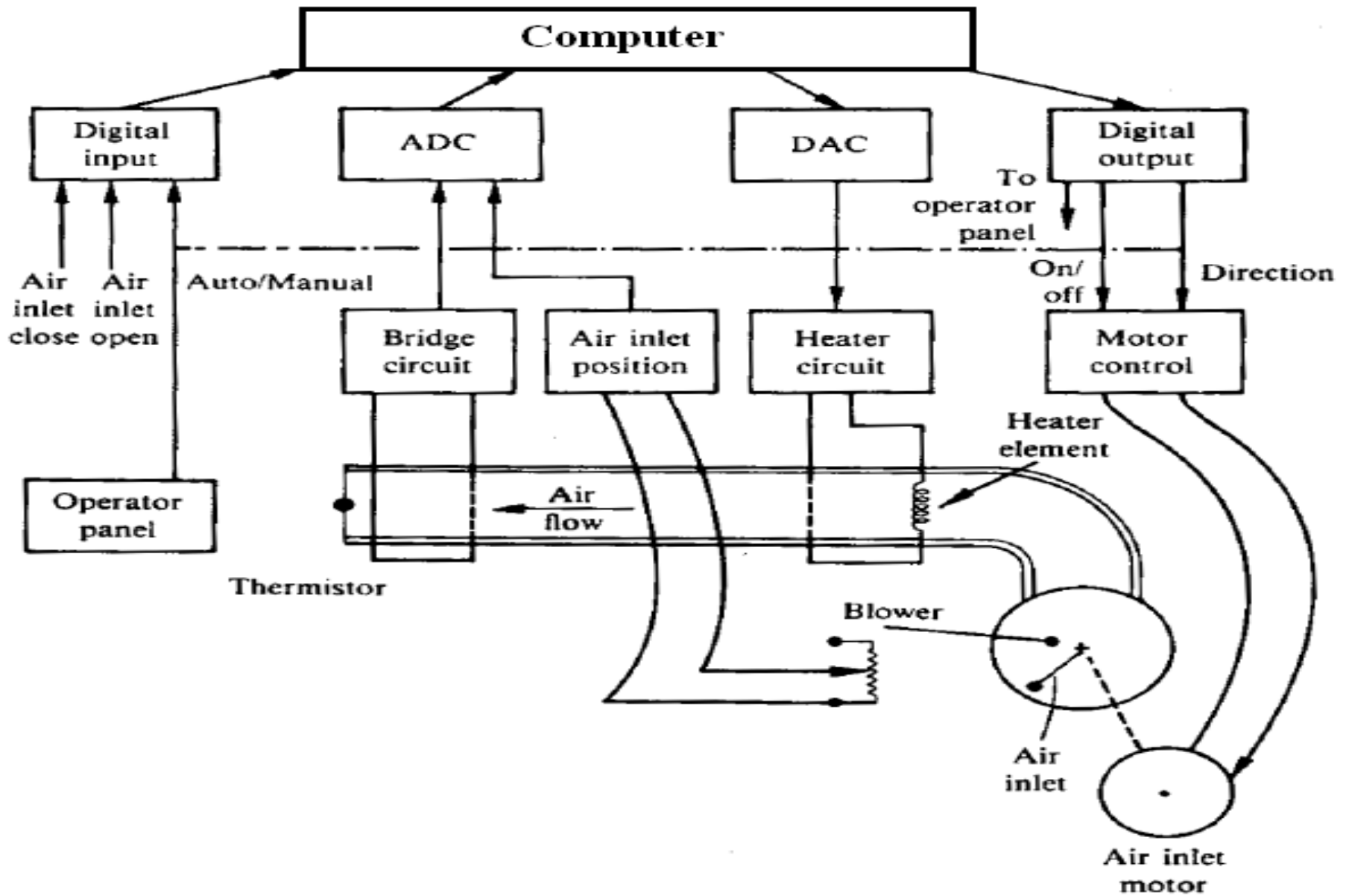

Overall Structure of RT Systems:

- Hardware (CPU, I/O devices, memory... etc)
 - Single CPU or more.
 - Clock selection.
- A real time Operating System: function as standard OS, with predictable behavior and well-defined functionality.
- A collection of RT tasks/processes (share resources, communicate/synchronize with each other and the environment)

Components of RT Systems

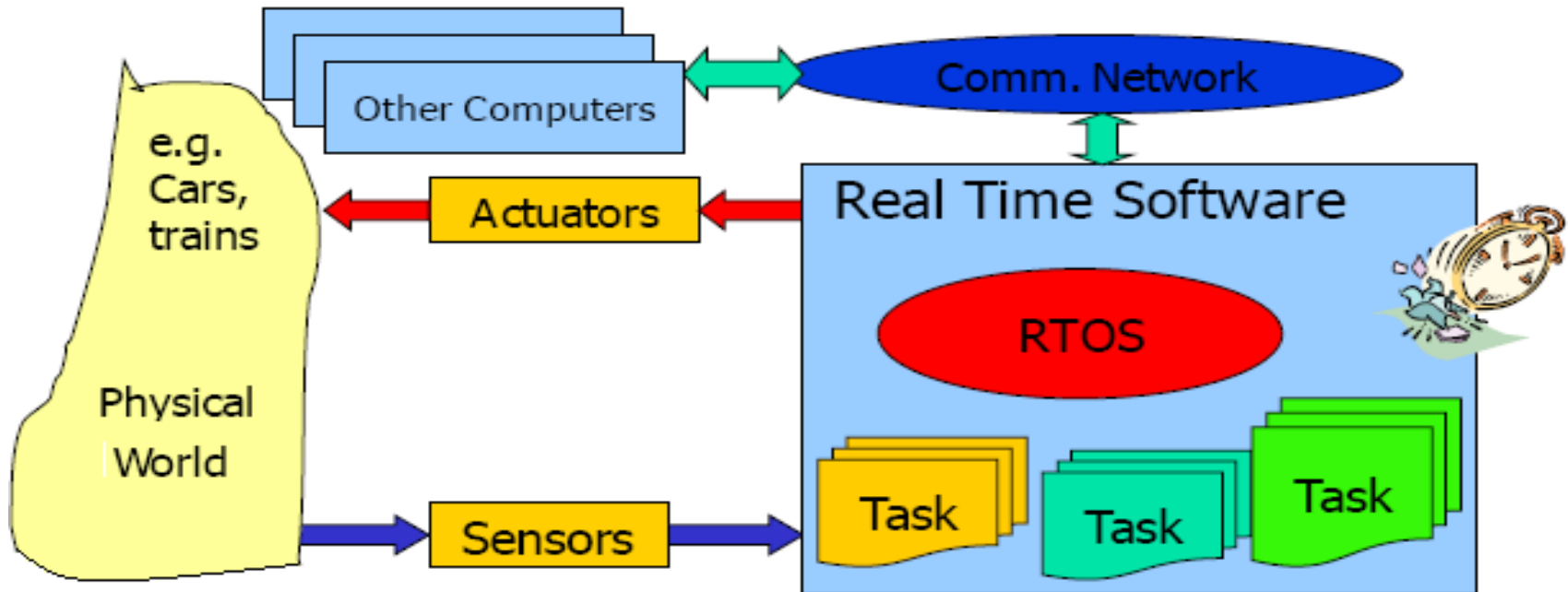

What is a Real-Time System?

➤ According to Oxford dictionary :

“Any system in which the O/P is produced is significant.”

➤ Alternative definitions :

- ❑ A RTS reads I/Ps from the plant and sends control signals to the plant at times determined by plant operational C/Cs.
- ❑ RTSs are those which must produce correct responses within a definite time limit.
- ❑ A RTS is any information processing system that has to respond to externally generated signal within a finite and specified period.
- ❑ A RTS is a computer system where the correct functioning of the system depends on the results produced and the time at which they are produced.

- ❑ A system, where correct timing behavior is strongly related to functionality, performance and reliability
- ❑ A computer system is a real-time one if it explicitly manages resources in order to meet timing constraints.
- ❑ A real-time system is a system where the correctness depends not only on the logical result of computation but also on the time at which the results are produced".
- ❑ A system that is synchronous with the interacting environment.
- ❑ In real-time systems:
 - **Timing of actions is essential:** Compare with table tennis, air bag, engine control and music.
 - **Age of data is essential:** Compare with a weather report: sample data, compute, actuate - when does the data cease to be valid?

Notes:

- Different consequences depending on context!
- Different types of timing requirements
- Delays need to be controlled!

Requirements on a real-time system:

1. Sufficiently fast (processing, communication, ...)
2. Predictable resource sharing and timing!

Classification of RTSs:

Real-Time systems can be classified as:

1. HARD REAL-TIME SYSTEM:

- A system whose operation is degraded if results are not proceeded according to specified timing requirements.
- System response occur within a specified deadline. Failure to meet such a timing requirement can have catastrophic consequences.
- Systems where it is absolutely imperative that responses occur within the required deadline. Example: Flight control systems, automotive systems, robotics etc.

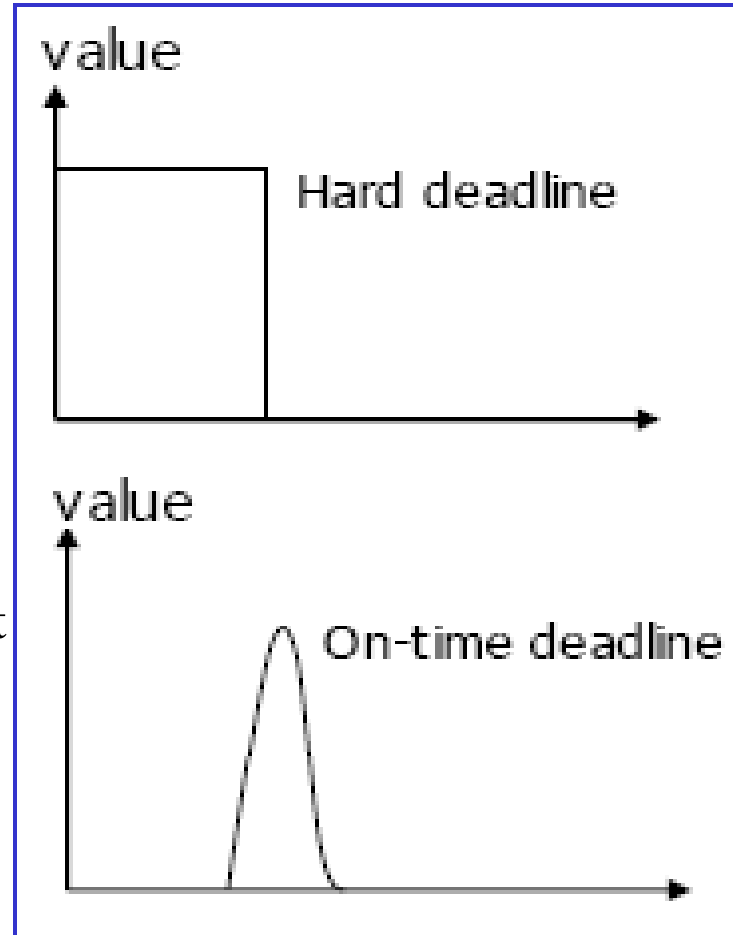

Classification of RTs: (Cont)

2. SOFT REAL-TIME SYSTEMS:

- A system whose operation is incorrect if results are not produced according to the timing constraints. Catastrophic results will happen then.
- The response times are important but not critical to the operation of the system . Failure to meet the timing requirements would not impair the system.
- Systems where deadlines are important but which will still function correctly if deadlines are occasionally missed. Example: Banking system, multimedia etc.

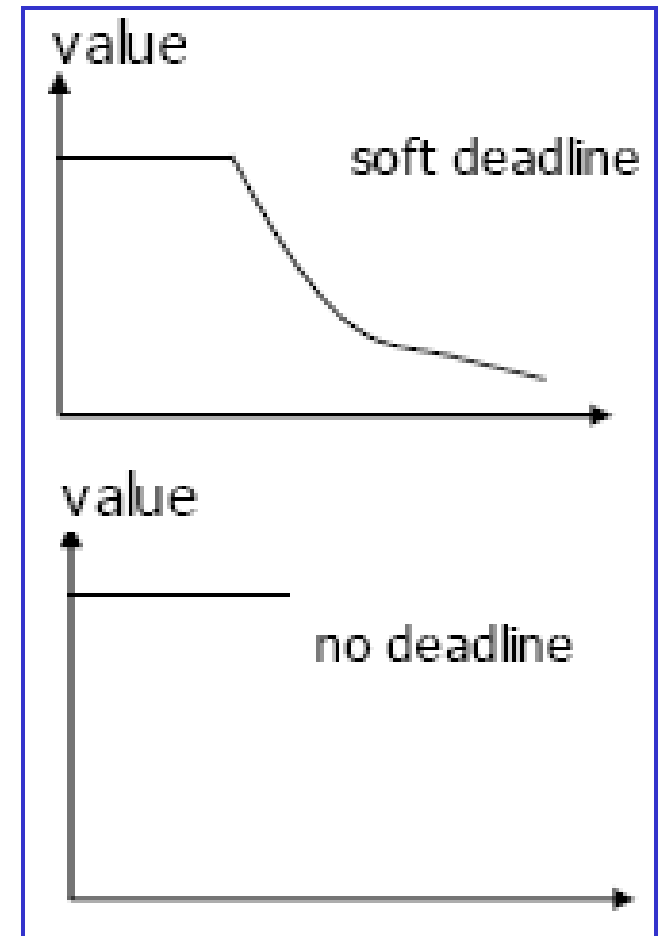

Classification of RTSs: (cont.)

3. FIRM REAL-TIME SYSTEMS: There is no value for a response that occurs past a specific deadline. Failure to meet the timing requirements is undesirable .

Notes:

- A single system may have both hard and soft real-time Subsystems.
- In reality many systems will have a cost function associated with missing each deadline.

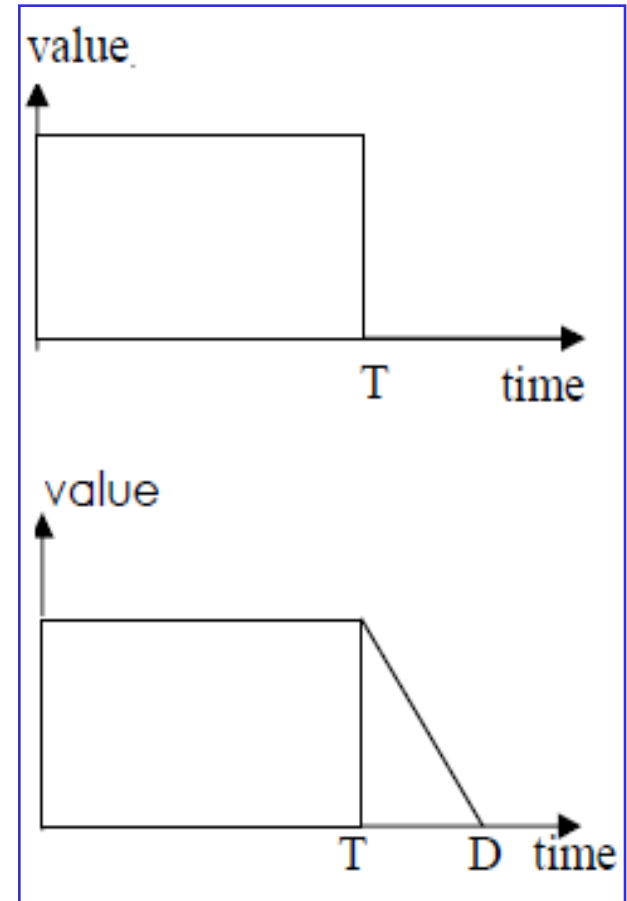

Clock-Based & Event-Based Systems:

- Synchronization between the external processes and internal actions (tasks) carried out by the computer may be defined in terms of the passage of time, or the actual time of day, in which case the system is said to be **“Clock-based system”** or it may be defined in terms of events, and the system is said to be **“Event-based system”**.
- If the relationship between the actions in the computer and the system is much more loosely defined, then the system is said to be **“interactive system”**.

Real-Time systems can be classified as:

1. Clock-Based Tasks: (Cyclic and Periodic):

- The completion of the operations within the specified time is dependent on the number of operations to be performed and the speed of the computer .
- Synchronization is usually obtained by adding a clock to the computer system , and using a signal from this clock to interrupt the operation of the computer at predetermined fixed time interval .

Plant time constant \longrightarrow **Sampling time (T_s)** \longrightarrow **Interrupt**

2. Event-Based Tasks: (A periodic):

- Action are to be performed not at particular times or time intervals but in response to some event . The system must respond within a given max. time to a particular event .
- Events occur at non-deterministic intervals and event-based tasks are referred to as “a periodic” task.

3. Interactive Systems:

- They represent the largest class of RTSs such as automatic bank tellers, reservation systems for hotels , airlines and car rental etc.
- The real-time requirement is usually expressed in terms such as “the average response time must not exceed
- Example: an automatic bank teller system might require an average response time not exceeding 20 sec.

Classification of Programs:

- A real-time program is defined as a program for which the correctness of operation depends on the logical results of the computation and the time at which the results are produced.

In general there are three types of programming:

1. **Sequential:** Actions are ordered as a time sequence , the program behavior depends only on the effects of the individual actions and their order .
2. **Multi-tasking:** Actions are not necessarily disjoint in time , it may be necessary for several actions to be performed in parallel .
3. **Real-Time:** Actions are not necessarily disjoint in time , and the sequence of some of program actions is not determined by the designer but the environment (by events occurring in the outside world which occur in real-time and without reference to the internal operations of the computer).

- A real-time program can be divided into a number of tasks but communication between the tasks can not necessarily wait for a synchronization signal. The environment task can not be delayed.
- In RT programs, the actual time taken by an action is an essential factor in the process of verification .

NOTES:

- RTSs have to carry out both periodic activities .
- RTSs have to satisfy time constraints that can be either:
 - A hard constraint , or
 - A soft (average value) constraint.
- RT software is more difficult to specify, design and construct than non real-time software .

Characteristics of a RTS:

- **Large and complex:** vary from a few hundred lines of assembler or C to 20 million lines of Ada estimated for the Space Station Freedom.
- **Concurrent control of separate system components:** devices operate in parallel in the real-world; better to model this parallelism by concurrent entities in the program.
- **Facilities to interact with special purpose hardware:** need to be able to program devices in a reliable and abstract way.
- **Mixture of Hardware/Software:** some modules implemented in hardware, even whole systems, SoC.
- **Extreme reliability and safety:** real-time systems typically control the environment in which they operate; failure to control can result in loss of life, damage to environment or economic loss
- **Guaranteed response times:** we need to be able to predict with confidence the worst case response times for systems; efficiency is important but predictability is essential