



Real-Time Systems (0630581)

Lecture (3)

Concepts of Real-Time Computer Control Systems

Prof. Kasim M. Al-Aubidy
Computer Engineering Department
Philadelphia University
Summer Semester, 2011

Lecture Outline:

- Concepts of computer control systems.
- Analog and digital control.
- Data acquisition system.
- Sequence control.
- Direct digital control.
- Adaptive control.
- Supervisory control.
- Centralized and distributed computer control.
- Human computer interface.

- The activities being carried out by a computer , in a RTS, will include the following:
 - Data acquisition .
 - Sequence control .
 - Direct digital control (DDC).
 - Supervisory control (SC).
 - Data analysis .
 - Data storage .
 - Human – computer interface (HCI).
- The objectives of using a computer in a RTS will include the following :
 - Efficiency of operation
 - Ease of operation .
 - Safety.
 - Improved products
 - Reduction in waste .
 - Reduced environmental impact .
 - Reduction in direct labor .

Sequence Control:

- Sequence control systems are widely used in the food processing and chemical industries.
- The procedure for this simple reactor are:
 1. Open valve A.
 2. Check the level of chemical 1.
 3. Start the stirrer to mix the chemical reactor.
 4. Repeat steps 1 and 2 with valve B.
 5. Switch ON the PID controller.
 6. Monitor the reaction temp, when it reaches the set-point, start a timer.
 7. When the timer indicates that the reaction is complete, switch OFF the controller and open valve C to cool down the reactor contents. Switch OFF the stirrer.
 8. Monitor the temp, when the contents have cooled, open valve E to remove the product from the reactor.

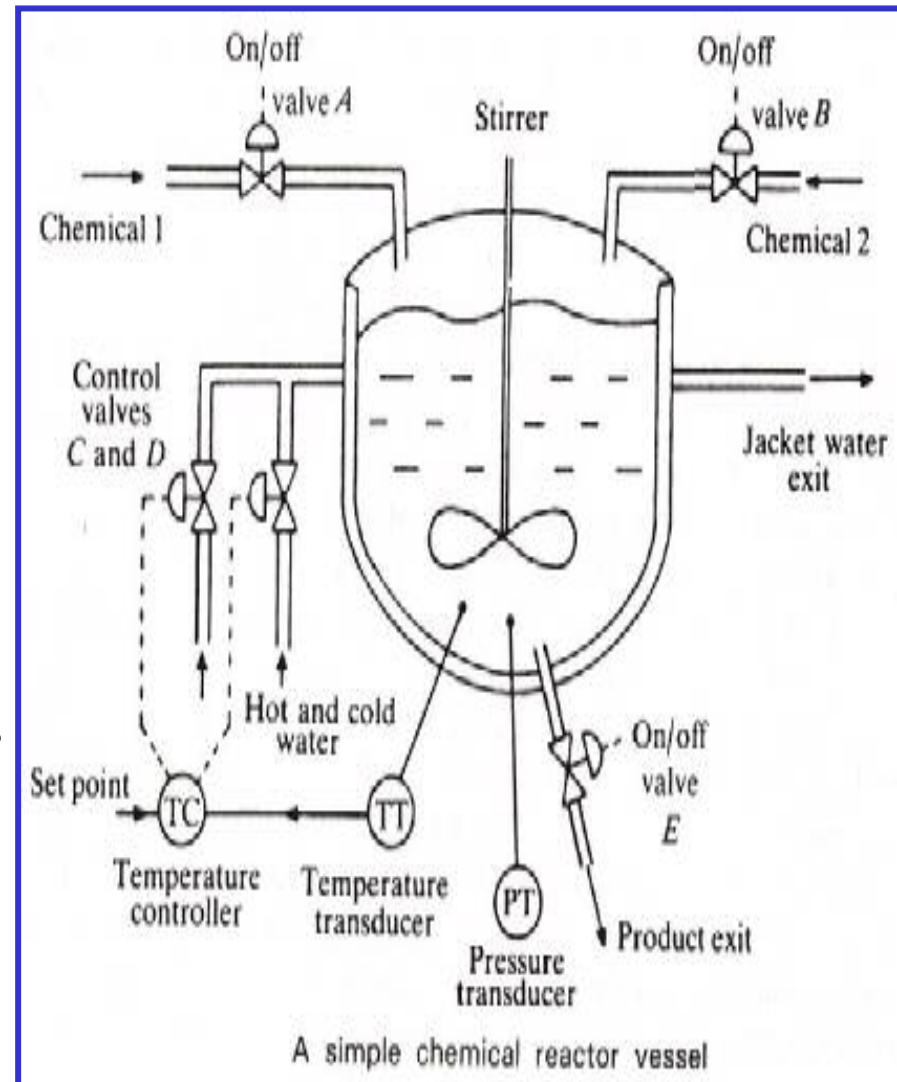

Direct Digital Control (DDC):

- The computer is in the feedback loop of the system. It is a critical component in terms of the reliability of the system.
- In the event of a failure of the computer, the system remains in a safe condition.
- The advantages for DDC over analog control are:
 1. Cost.
 2. Performance.
 3. Safety.

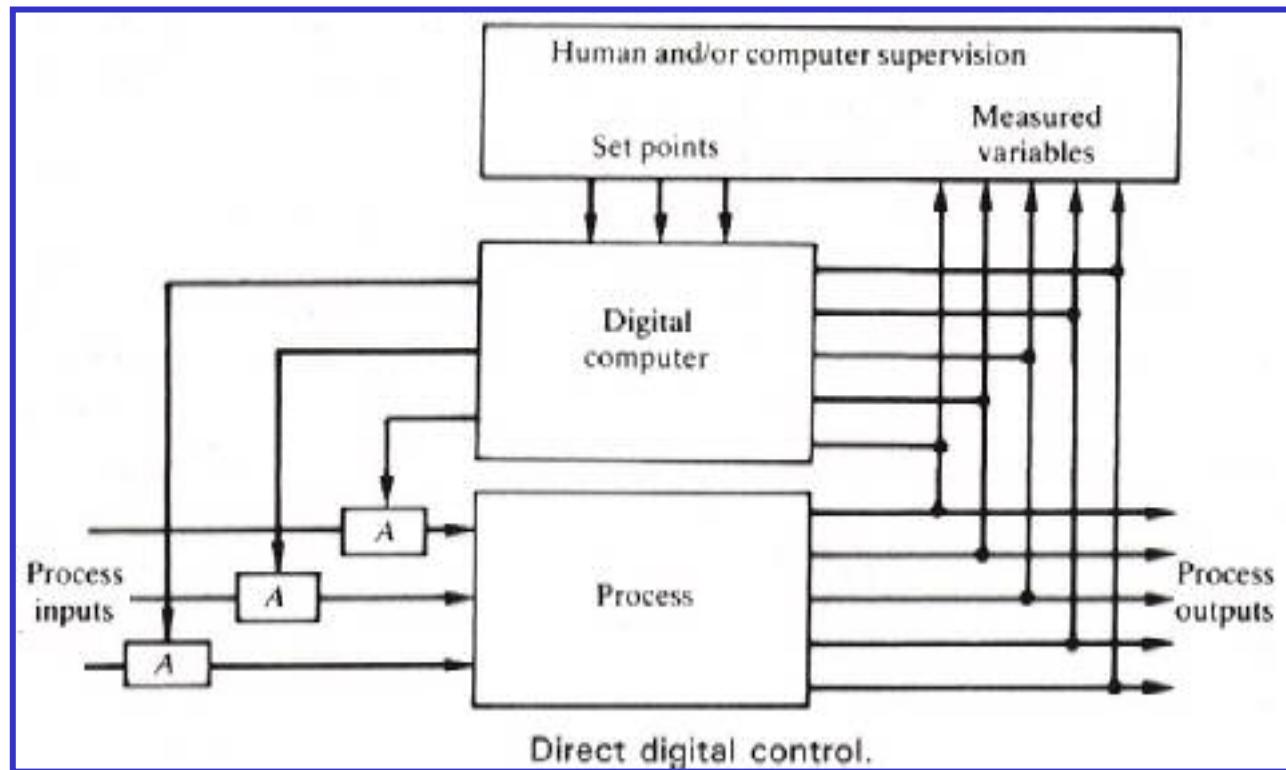

Adaptive Control:

Adaptive control can take several forms. Three of the most common are:

1. Preprogrammed adaptive control.
2. Self-tuning control.
3. Model-reference adaptive control.

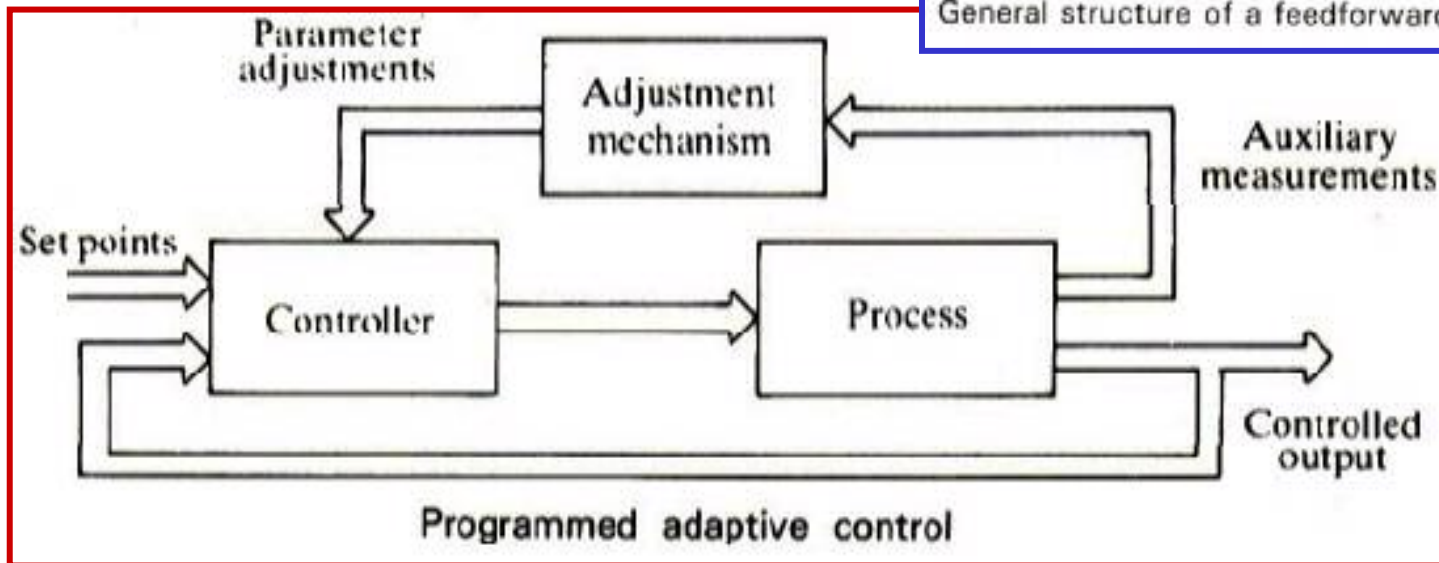
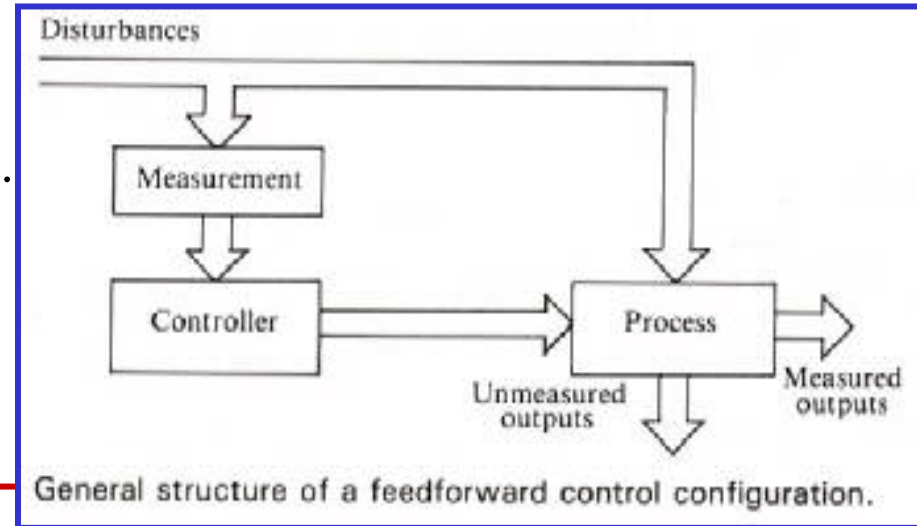

Supervisory Control:

- Many of early computer control schemes used the computer in a supervisory role and not for DDC. The main reason for this were;
 1. Computers were not always very reliable and caution dictated that the plant should still be able to run in the event of a computer failure.
 2. computers were very expensive and it was not economically viable to replace the analog control equipment in current use.

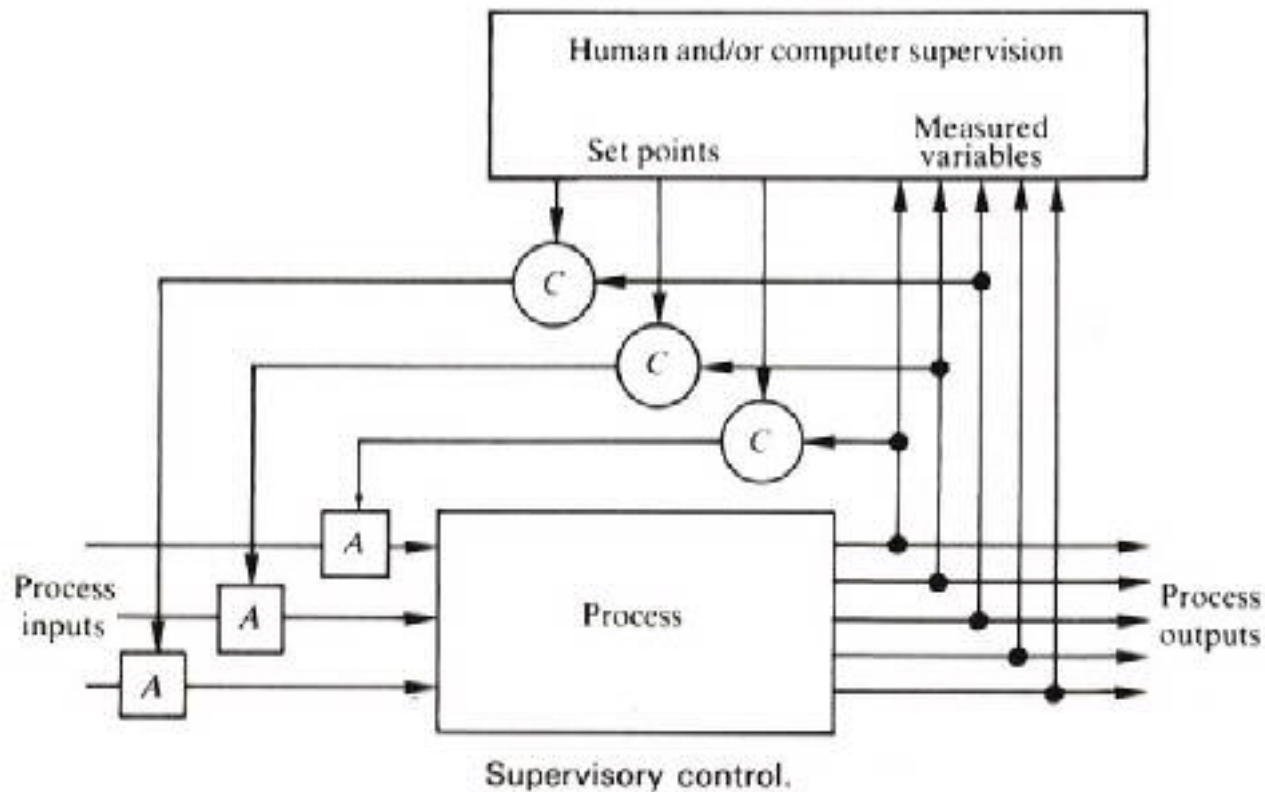

Centralized Computer System:

- Most of the 1960s computer control systems implied the use of one central computer for the control of the whole plant. The reason for this was largely financial (computers were expensive).
- By 1970 the cost of computer hardware had reduced to such an extent that it became feasible to consider the use of dual computer systems.
- Automatic failure and change-over equipment when used becomes a critical component.
- The continued reduction of the cost of hardware and the development of the microprocessor has made multi-computer systems feasible. These fall into two types:
 1. Hierarchical systems : tasks are divided according to function, e.g.: one computer performing DDC.
 2. Distributed systems : many computers perform essentially similar tasks in parallel.

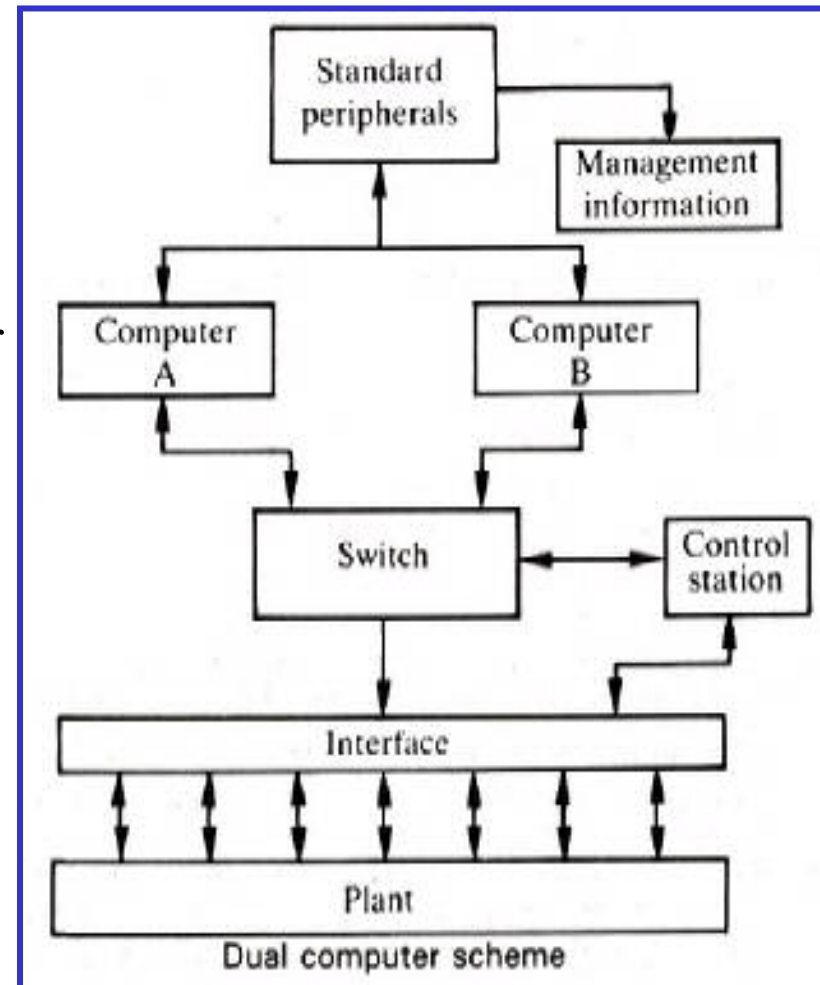

Mlti-Compter Systems:

- Several computers can be configured for real-time computer control applications.
 - These include dual computer systems to increase reliability, and distributed and hierarchical configurations.
1. **Hierarchical Systems:** tasks are divided according to function, for example; one computer performing DDC, other performing sequence control, other performing supervisory control..
 2. **Distributed Systems:** many computers perform essentially similar tasks in parallel.

Hierarchical Decision Making:

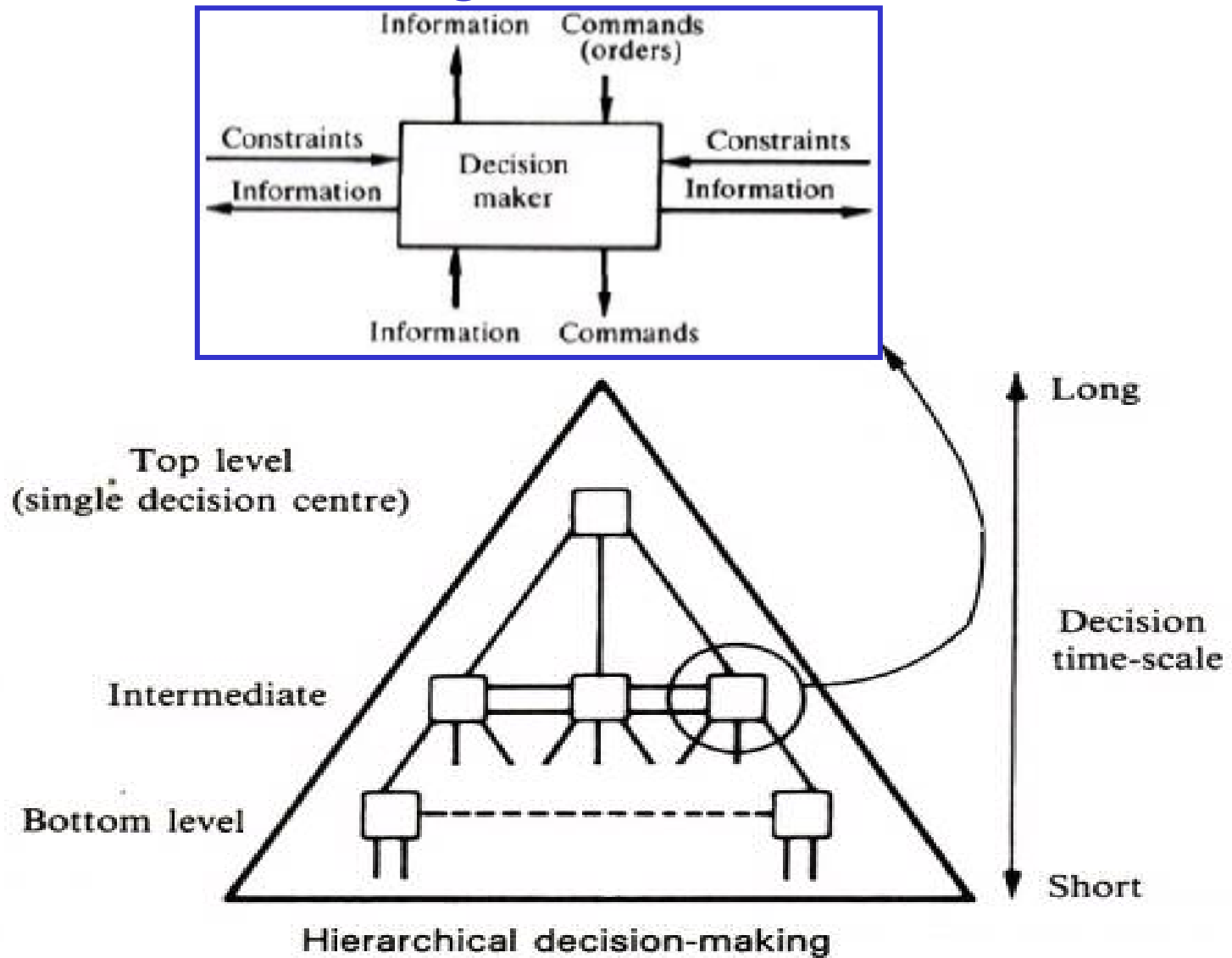

Hierarchical System: An Example

- A typical example of a hierarchical system is the batch system given below.
- It has three levels; Manager, Supervisor, and unit Control.
- It is assumed that single computers are used for manager and supervisor functions, and that for each processing unit a single unit control computer is used.

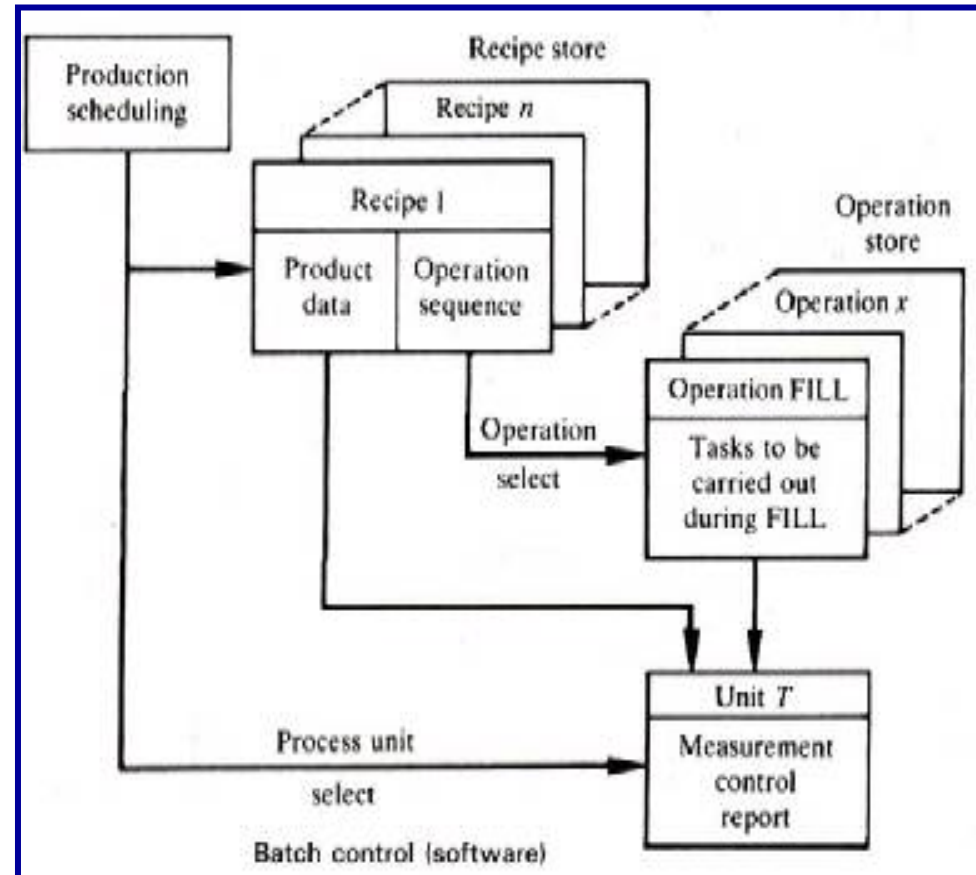
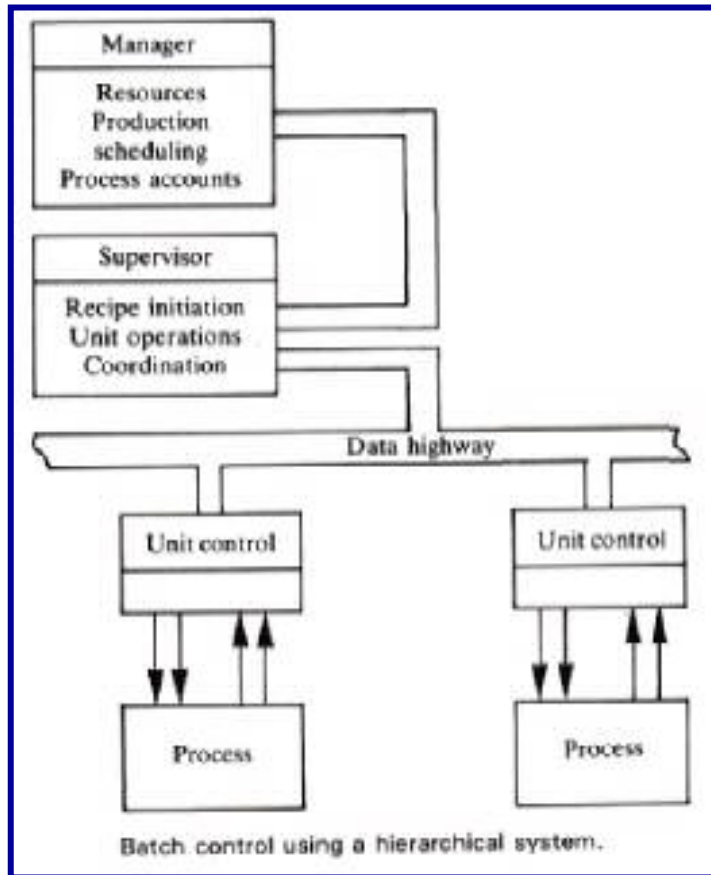

Distributed Systems:

In real-time systems , consider:

- Each unit is carrying out essentially similar tasks to all the other units.
- In the event of failure or overloading of a particular unit all or some of the work can be transferred to other units.

Advantages:

1. Sharing of tasks between μ Cs.
2. More flexible than using one μ C.
3. Failure of a unit will cause less disruption.
4. It is easier to make changes .
5. Linking by serial highway means that the computer units can be widely dispersed .

