



Real-Time Systems

(0630581)

Lecture (4)

Computer Hardware Requirements for Real-Time Applications

Prof. Kasim M. Al-Aubidy
Computer Engineering Department
Philadelphia University
Summer Semester, 2011

Lecture Outline:

- Features of microcomputers and microcontrollers.
- Standard interfacing techniques.
- Digital input/output interface.
- Analog input/output interface.
- Pulse input/output interface.
- Data acquisition system design.
- Management of data acquisition system.

Microcomputers & Microcontrollers:

- General purpose microprocessors include the Intel xx86 series, Motorola 680xx series, National 32xxx series, and the Zilog Z8000 series.
- The ALU together with control unit and the general purpose registers make up the CPU.
- The CPU, memory and input/output units represent a microcomputer. The CPU in a single chip microcomputer or a microcomputer board is called microprocessor.

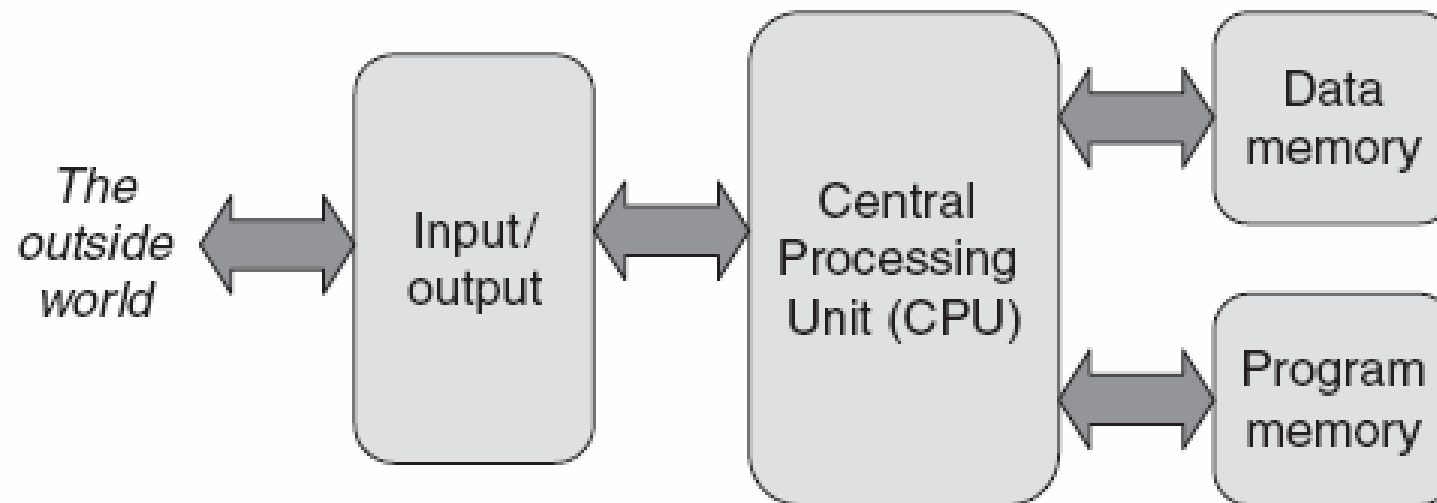

Computer Architecture:

1. The Von Neumann System.
2. The Harvard System.

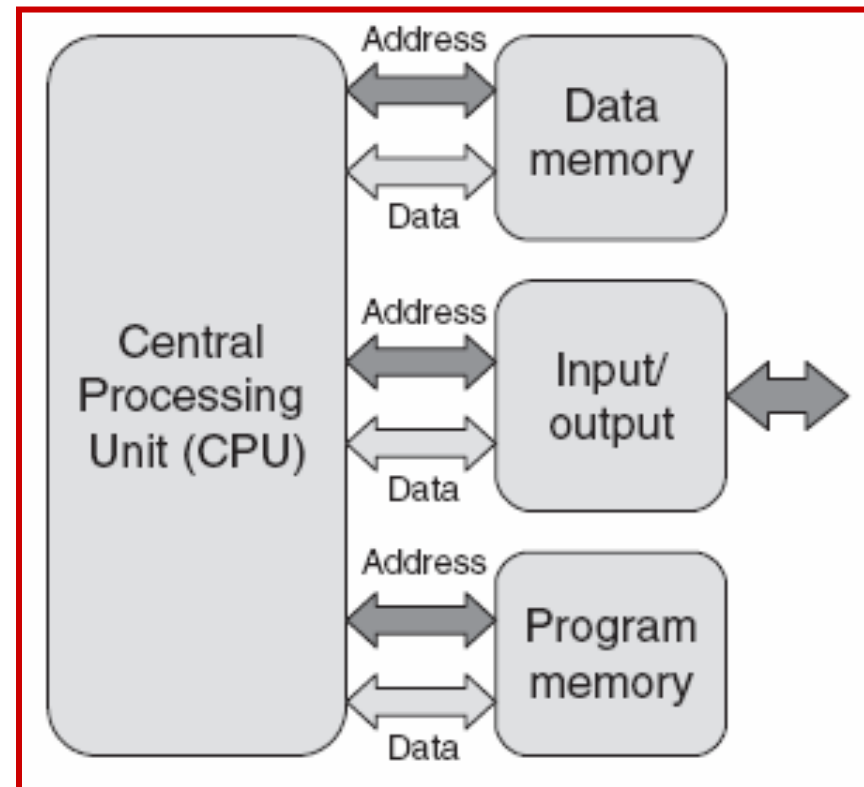
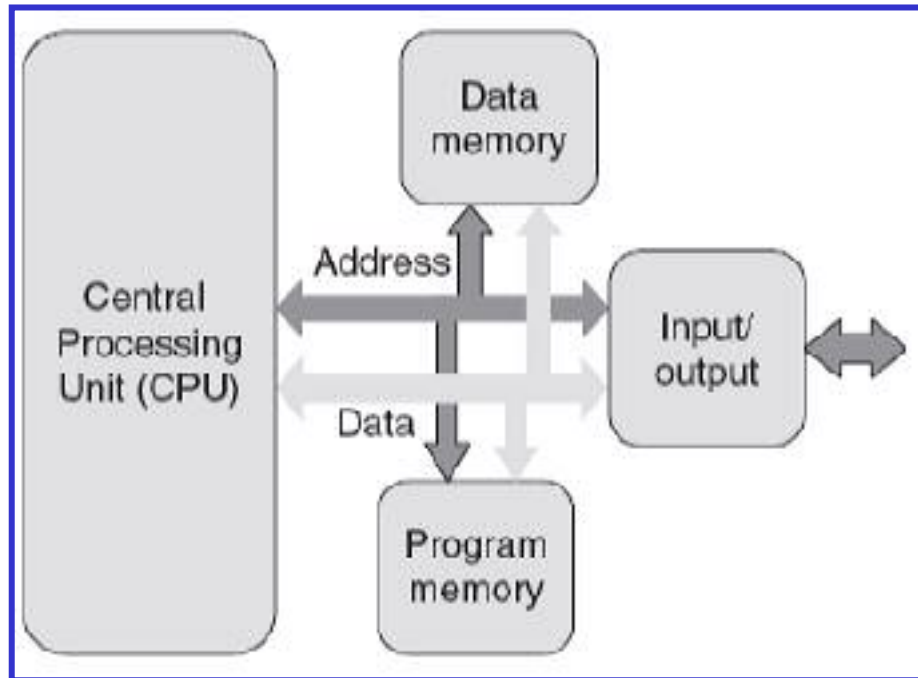

General-Purpose Computer :

1. CPU : Features :

- Word length.
- Addressing methods.
- Information transfer rates.
- Instruction set .
- No. of registers.
- Interrupt structure.

2. Storage:

- RAM, ROM, EPROM and auxiliary storage unit .
- DMA for fast I/O information transfer.

3. Input and Output:

- Process I/O
- Operator I/O
- Computer I/O

4. Bus structure:

- Mechanical (physical) structure
- Electrical
- Functional

Specialized Computers:

- Specialized processors have been developed for two main purposes:
 - Safety-critical applications.
 - Increased computation speed .
- For safety-critical applications , use RISC computers.
- The advantage of simplifying the instruction set is:
 1. The possibility of formal verification (using math. proofs) that the logic of the processor is correct.
 2. It is easier to write assemblers and compilers for simple instruction set.
- Many different forms of parallel computer architecture have been used SIMD, MISD, and MIMD .
- Digital signal processors .

Single Chip Microcontrollers:

- Small amount of RAM and EPROM , it can be extended .
- Instruction set .
- DAC and ADC
- Interrupt structure
- I/O lines .
- Timers.

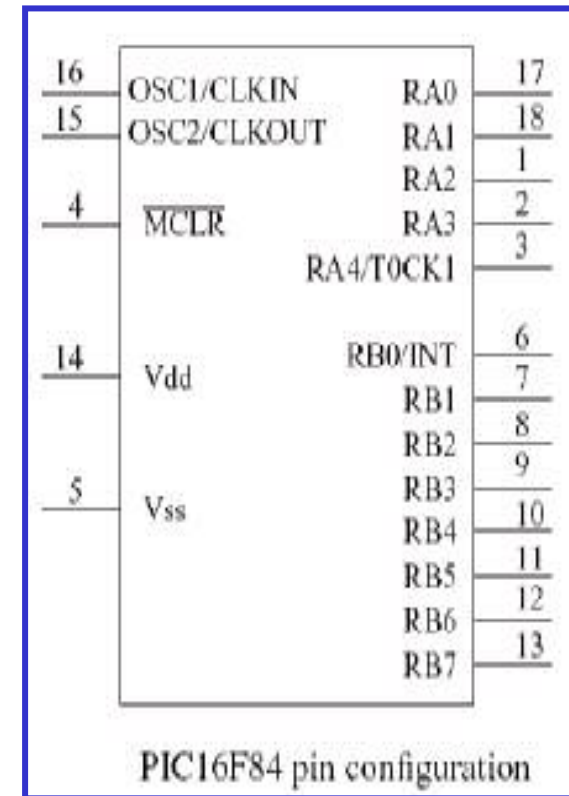
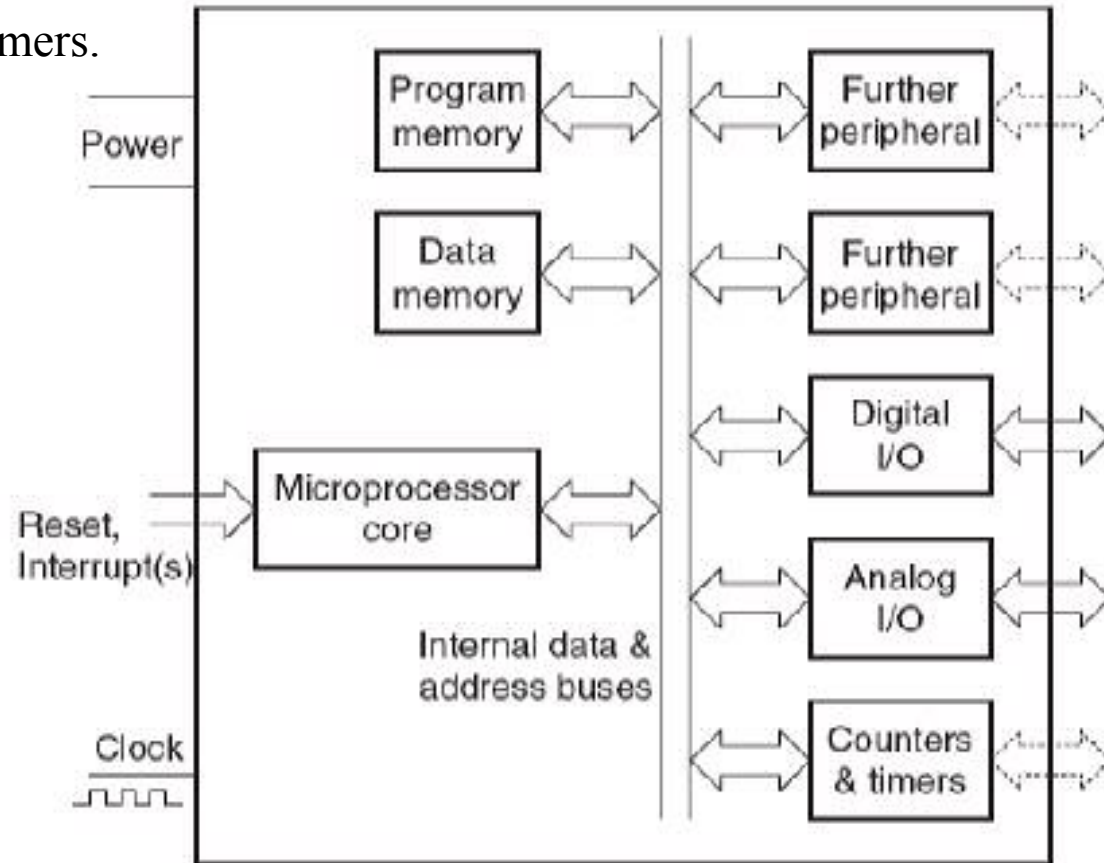

Microcontroller Selection:

Comparison of PIC families

PIC family	Stack size (words)	Instruction word size	Number of instructions	Interrupt vectors
12CXXX/12FXXX	2	12- or 14-bit	33	None
16C5XX/16F5XX	2	12-bit	33	None
16CXXX/16FXXX	8	14-bit	35	1
17CXXX	16	16-bit	58, including hardware multiply	4
18CXXX/18FXXX	32	16-bit	75, including hardware multiply	2 (prioritised)

Device number	No. of pins ^o	Clock speed	Memory (K = Kbytes, i.e. 1024 bytes)	Peripherals/special features
16F84A	18	DC to 20 MHz	1K program memory, 68 bytes RAM, 64 bytes EEPROM	1 8-bit timer 1 5-bit parallel port 1 8-bit parallel port
16F873A	28	DC to 20 MHz	4K program memory 192 bytes RAM, 128 bytes EEPROM	3 parallel ports, 3 counter/timers, 2 capture/compare/PWM modules, 2 serial communication modules, 5 10-bit ADC channels, 2 analog comparators
16F874A	40	DC to 20 MHz	4K program memory 192 bytes RAM, 128 bytes EEPROM	5 parallel ports, 3 counter/timers, 2 capture/compare/PWM modules, 2 serial communication modules, 8 10-bit ADC channels, 2 analog comparators

The PIC16F84 Microcontroller:

- The 16F84A architecture is representative of all 16 Series microcontrollers, with Harvard structure, pipelining and a RISC instruction set.
- The PIC 16F84A has a limited set of peripherals, chosen for small and low-cost applications. It is thus a smaller member of the family, with features that are a subset of any of the larger ones.
- A particular type of memory location is the Special Function Register, which acts as the link between the CPU and the peripherals.
- Reset mechanisms ensure that the CPU starts running when the appropriate operating conditions have been met, and can be used to restart the CPU in case of program failure.
- The parallel port allows ready exchange of digital data between the outside world and the controller CPU.
- It is important to understand the electrical characteristics of the parallel port and how they interact with external elements.
- A microcontroller needs a clock signal in order to operate. The characteristics of the clock oscillator determine speed of operation and timing stability, and strongly influence power consumption.
- Interrupts and counter/timers are important hardware features of almost all microcontrollers. They both carry a number of important hardware and software concepts, which must be understood.

Communications:

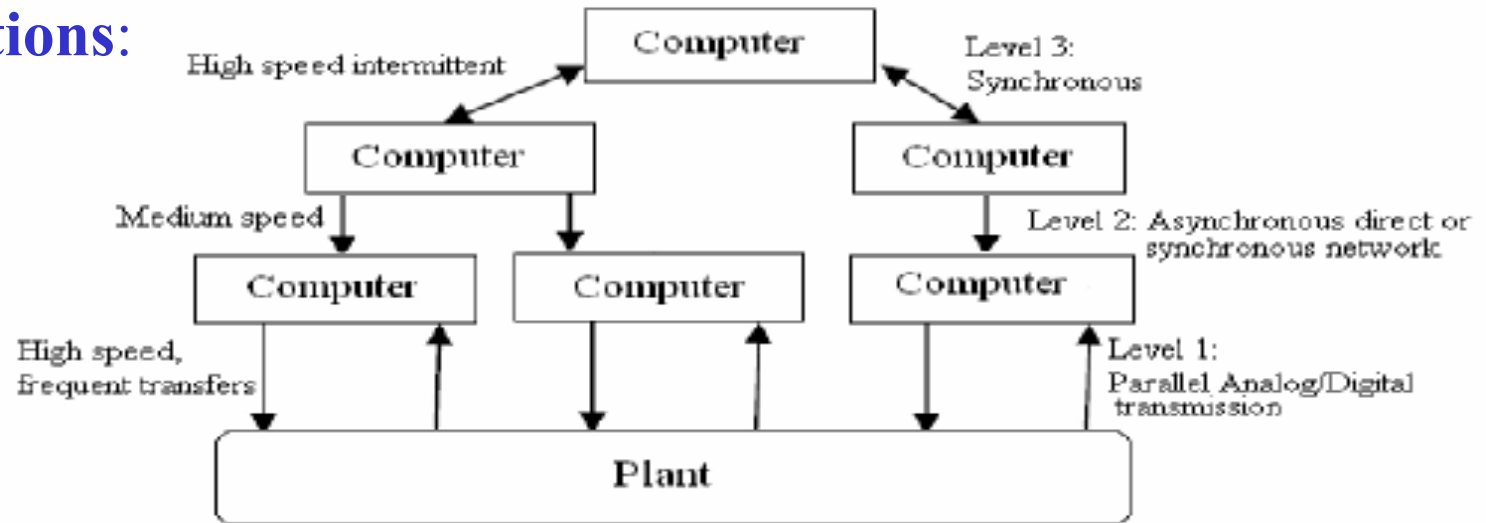

- Level (1): parallel analog/digital transmission (High speed, frequent transfer)
- Level(2): Asynchronous direct or synchronous network (Medium speed)
- Level (3): Synchronous (High speed , intermittent)
- At high levels, it is more usual to use serial communication methods due to the distances between computers (few hundred meters).
- At plant level , parallel analog and digital signal transmission techniques are involved, since the distances are small.
- Serial communication techniques can be characterized in several ways:
 1. Mode: Synchronous and Asynchronous .
 2. Quantity: Character by character and block .
 3. Distance: Local and remote (Wide area).
 4. Code: ASCII and others.

Process Related Interface:

- Instruments and actuators connected to the plant can take a wide variety of forms; they may be used for measuring a variable, they could be used to control an actuator.
- There is a need to convert a digital quantity to a physical quantity, or an analog signal generated from a sensor into a digital quantity.
- Most devices can be allocated to one of the following categories;
 1. Digital quantities.
 2. Analog quantities.
 3. Pulses and pulse rates.
 4. Telemetry.

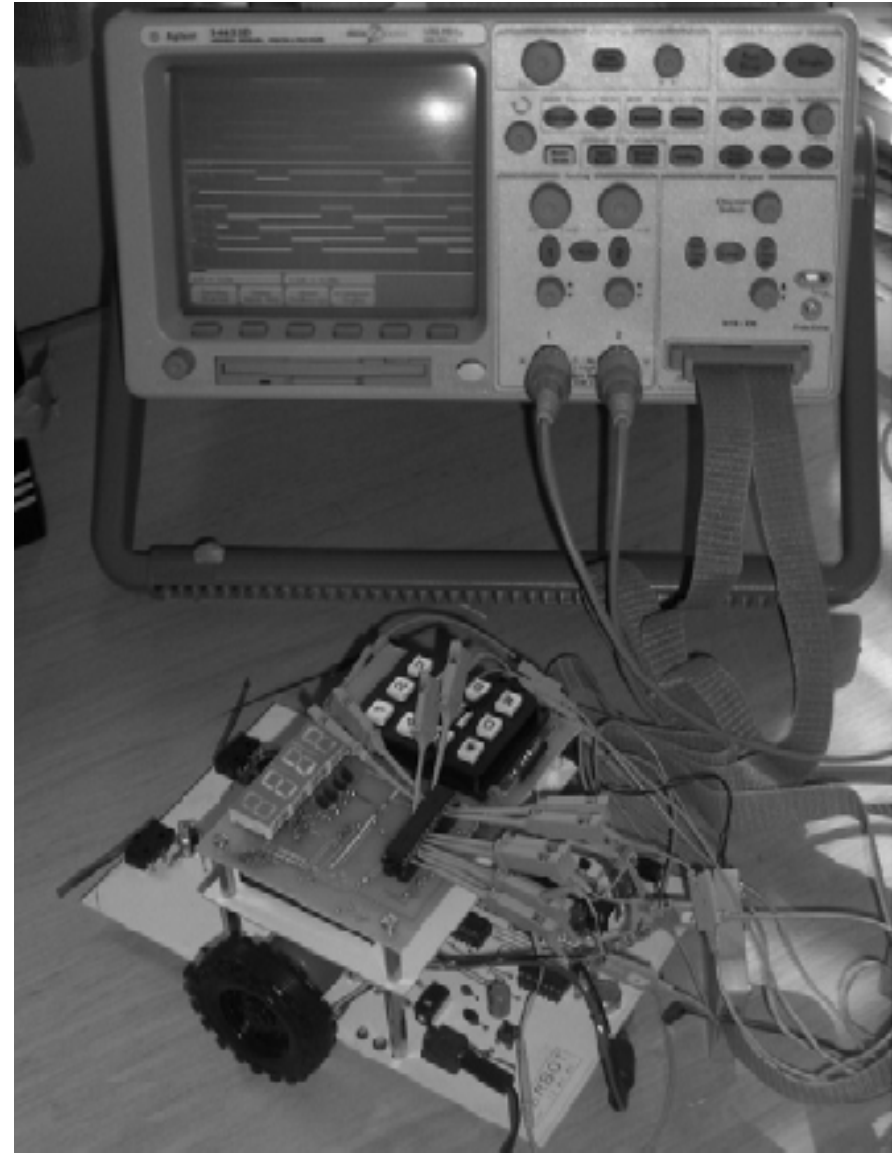

SENSORS USED IN RT SYSTEMS:

- A sensor is a device that outputs a signal which is related to the measurement of a physical quantity such as temperature, speed, force, pressure, displacement, acceleration, torque, flow, light or sound.
- Sensors are used in RT systems in the feedback loops, and they provide information about the actual output of a plant. For example, a speed sensor gives a signal proportional to the speed of a motor.
- Sensors can be classified as analog or digital;
 - **Analog sensors** are more widely available, and their outputs are analog voltages. For example, the output of an analog temperature sensor may be a voltage proportional to the measured temperature. Analog sensors can only be connected to a computer by using an A/D converter.
 - **Digital sensors** are not very common and they have logic level outputs which can directly be connected to a computer input port.
- The choice of a sensor for a particular application depends on many factors such as the cost, reliability, required accuracy, resolution, range and linearity of the sensor.

The choice of a sensor:

- **Range:** The range of a sensor specifies the upper and lower limits of the measured variable for which a measurement can be made. For example, if the range of a temperature sensor is specified as 10–60 °C then the sensor should only be used to measure temperatures within that range.
- **Resolution:** The resolution of a sensor is specified as the largest change in measured value that will not result in a change in the sensor's output, i.e. the measured value can change by the amount quoted by the resolution before this change can be detected by the sensor. In general, the smaller this amount the better the sensor is, and sensors with a wide range have less resolution. For example, a temperature sensor with a resolution of 0.001K is better than a sensor with a resolution of 0.1 K.
- **Repeatability:** The repeatability of a sensor is the variation of output values that can be expected when the sensor measures the same physical quantity several times. For example, if the voltage across a resistor is measured at the same time several times we may get slightly different results.
- **Linearity:** An ideal sensor is expected to have a linear transfer function, i.e. the sensor output is expected to be exactly proportional to the measured value. However, in practice all sensors exhibit some amount of nonlinearity depending upon the manufacturing tolerances and the measurement conditions.
- **Dynamic response:** The dynamic response of a sensor specifies the limits of the sensor characteristics when the sensor is subject to a sinusoidal frequency change. For example, the dynamic response of a microphone may be expressed in terms of the 3-dB bandwidth of its frequency response.

Analog Input/Output Interfacing:

Some properties of analog and digital quantities

Property	Analog	Digital
Means of (electrical) representation	A continuously variable voltage, or current, represents the variable.	Variable is represented by a binary number.
Precision of representation	Can take infinite range of values; absolute precision is theoretically possible, as long as signal is kept completely uncorrupted.	Only a fixed number of digit combinations are available to represent measure; for example, an 8-bit number has only 256 different combinations. 'Continuously variable' quality of analog signal cannot be replicated.
Resistance to signal degradation	Almost inevitably suffers from drift, attenuation, distortion, interference. Cannot completely recover from these.	Digital representation is intrinsically tolerant of most forms of signal degradation. Error checking can also be introduced and with appropriate techniques complete recovery of a corrupted signal can be possible.
Processing	Analog signal processing using op amps and other circuits has reached sophisticated levels, but is ultimately limited in flexibility and always suffers from signal degradation.	Fantastically powerful computer-based techniques available.
Storage	Genuine analog storage for any length of time is almost impossible.	All major semiconductor memory technologies are digital.

Pulse Input/Output Interfacing:

- Reading sequence of pulses generated from a sensor.
- Reading the width of a pulse width modulated signal.
- Generating number of pulses with fixed frequency.
- Generating a controllable pulse width modulated signal.
- Several design circuits will be considered during lecture.

Example:

Simple Robot System: Hardware interfacing with an 8-bit microcontroller.

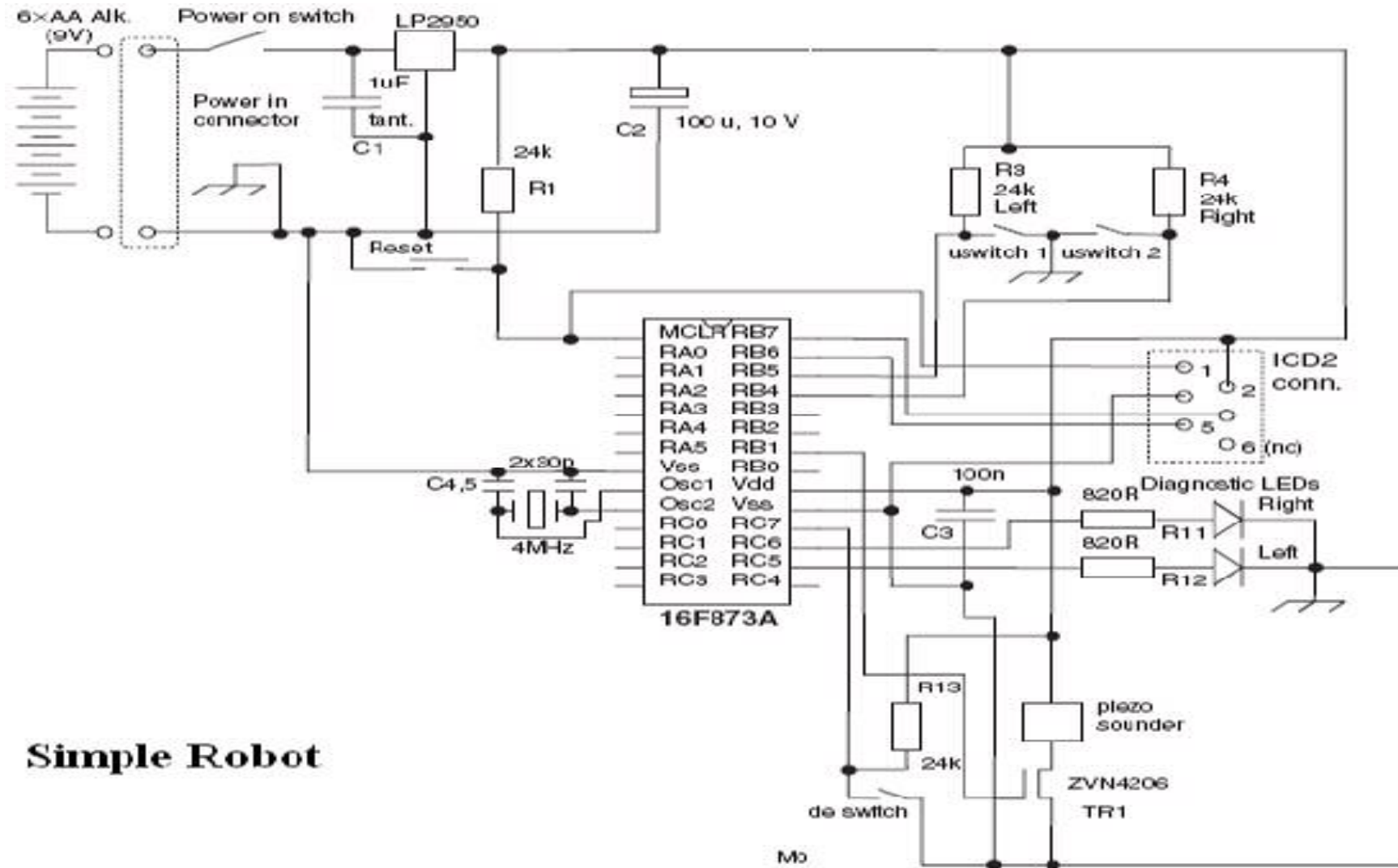

Simple Robot

Keypad circuit diagram with pull-up resistor:

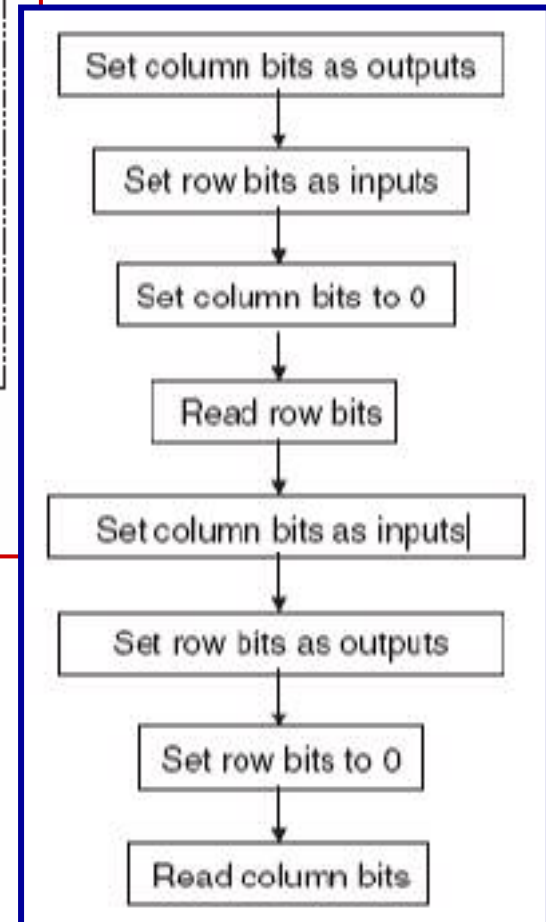
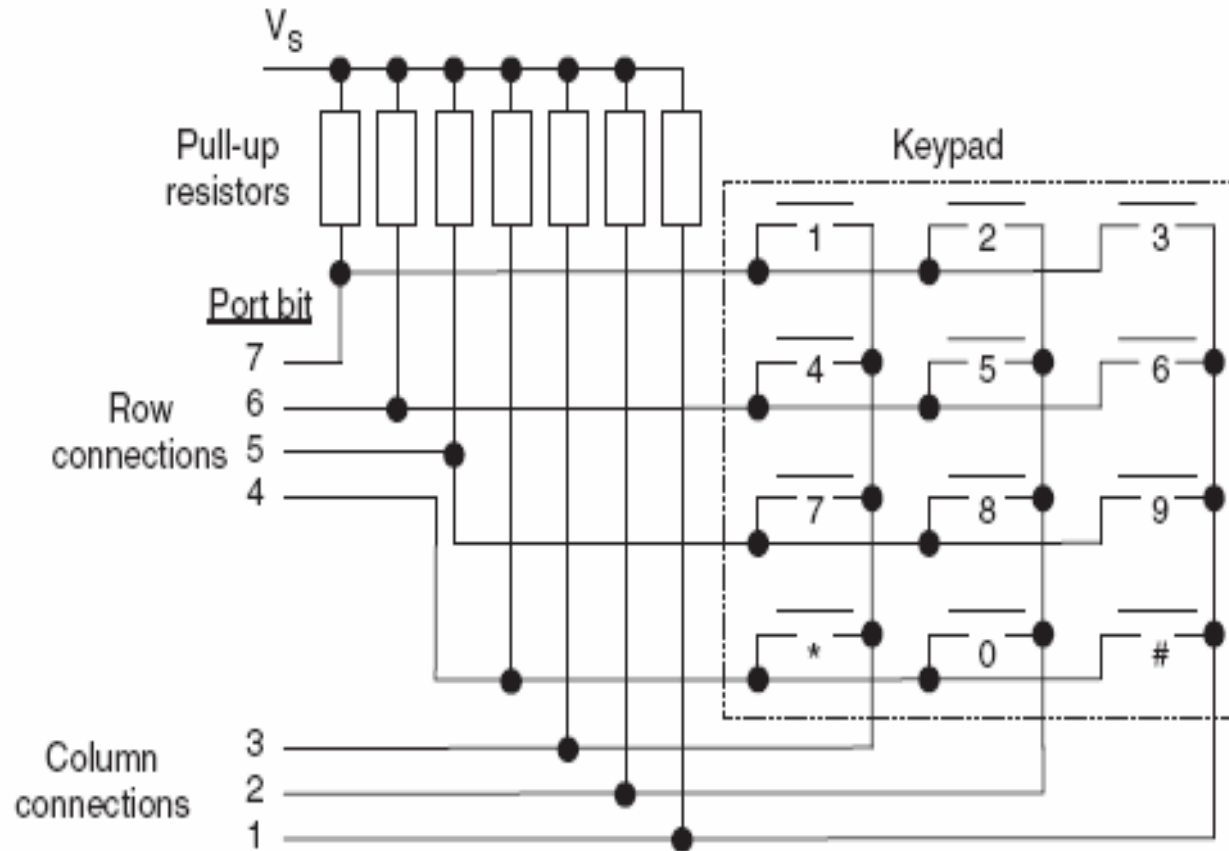

Example:

Four-digit display unit design.

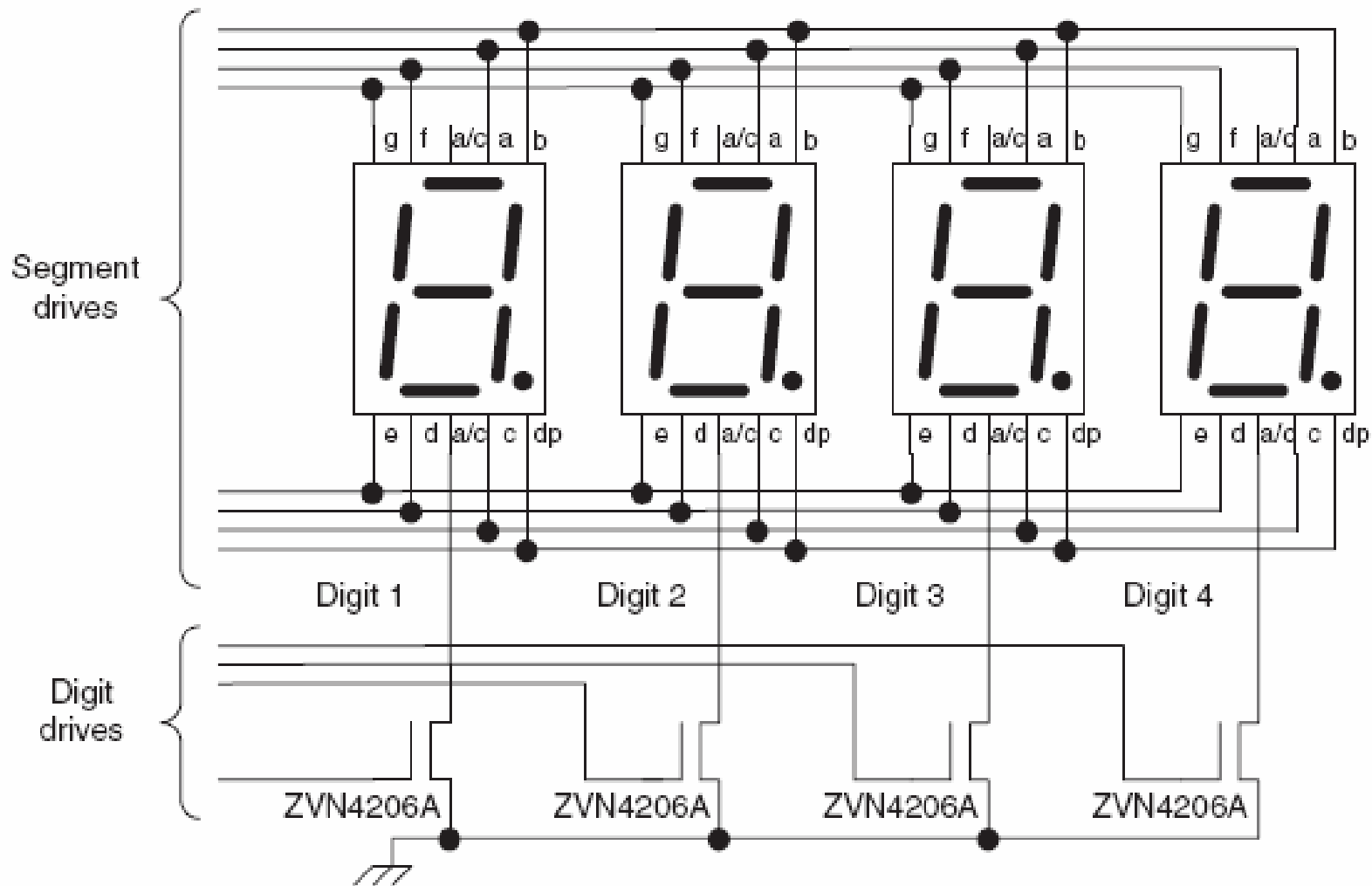

Example:

LCD interfacing with an 8-bit microcontroller.

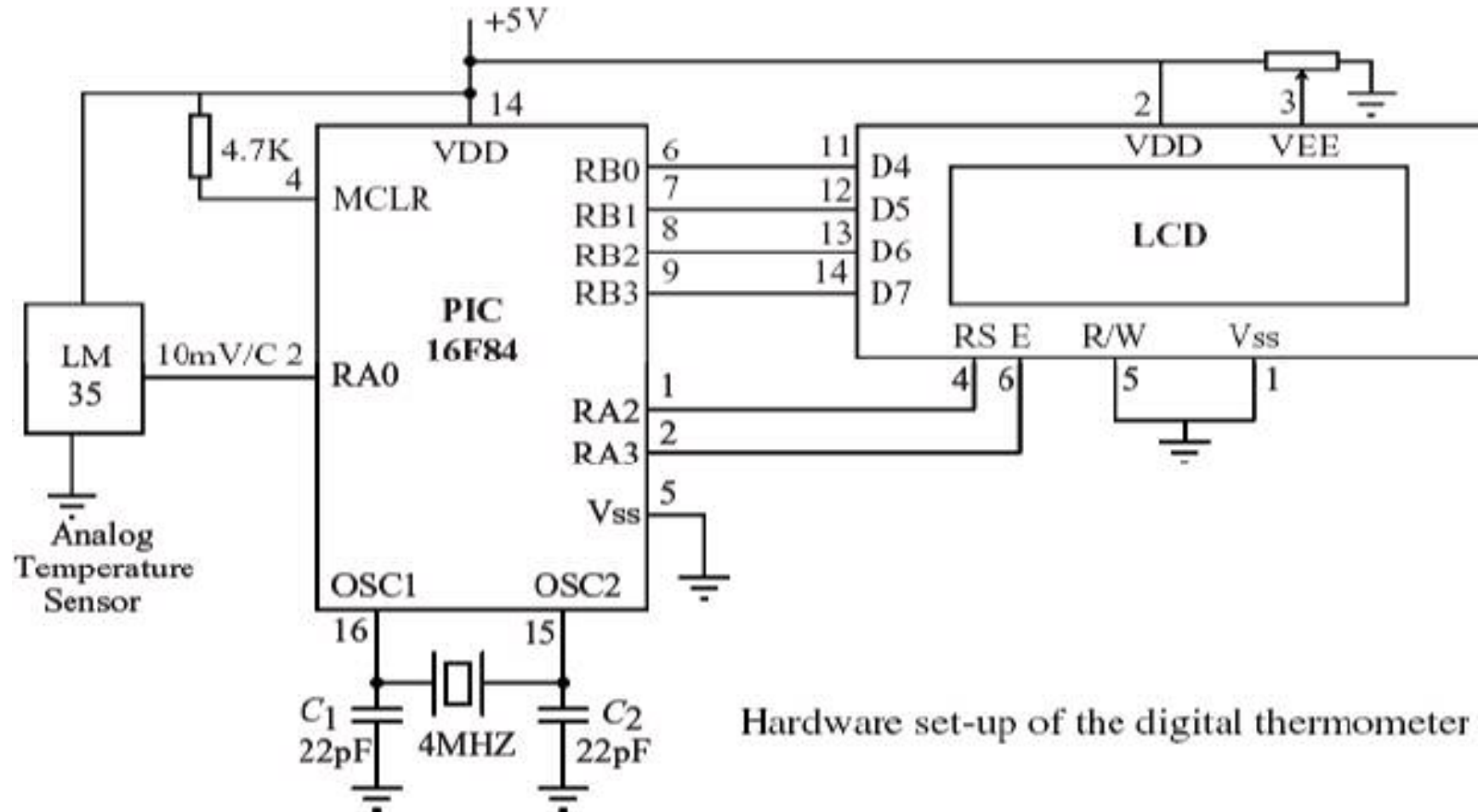

Hardware set-up of the digital thermometer

Data Acquisition System Design:

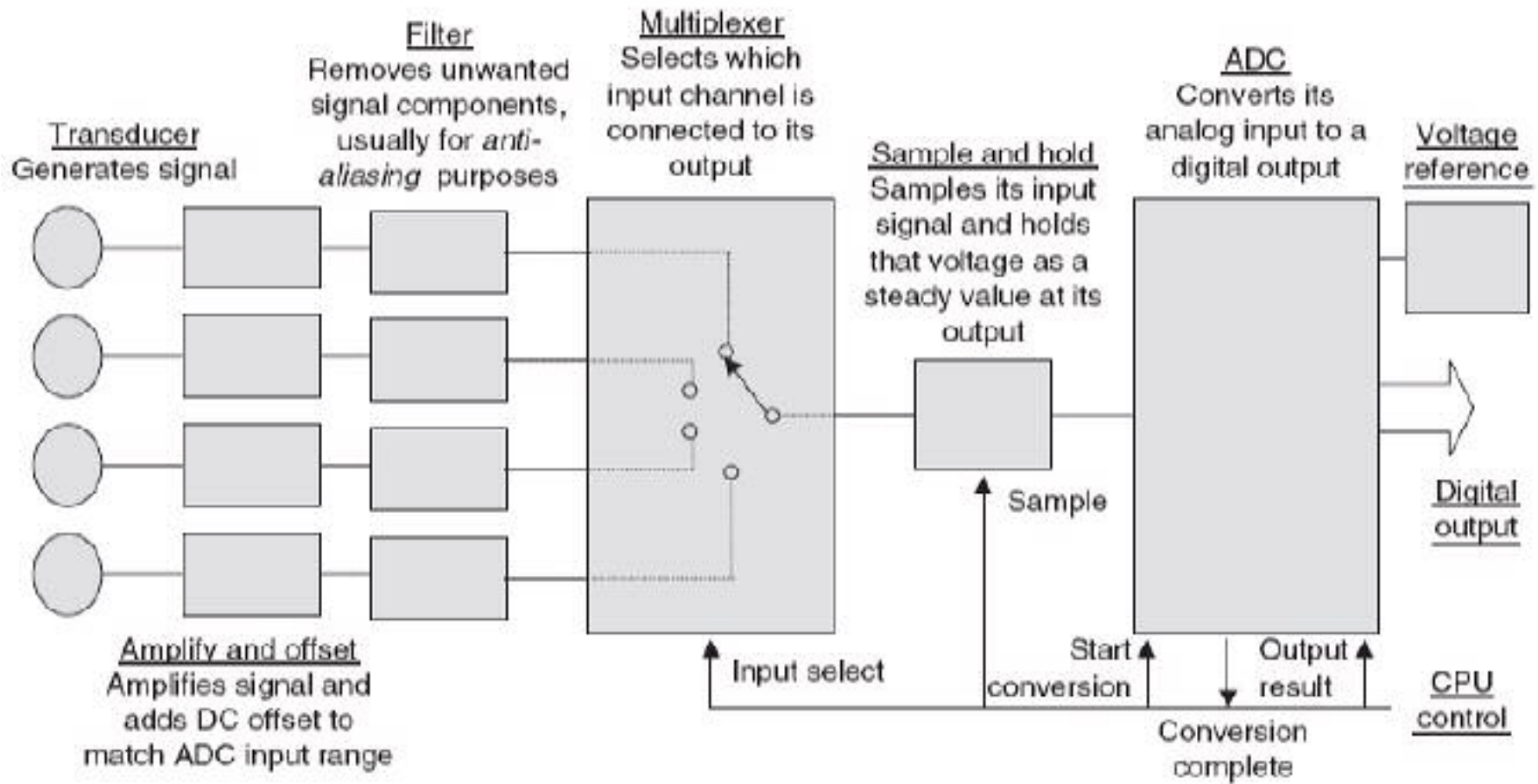

Elements of a (four-channel) data acquisition system

DAS: Software Design:

- Using flowchart.
- Writing an assembly program.
- Different sampling rates.
- Selecting the suitable sampling frequency.
- Task execution time.
- Dealing with interrupts.
- Memory management.

