



NOVEL TECHNIQUE TO CONTROL THE PREMATURE INFANT INCUBATOR SYSTEM USING ANN

Dr. Ghada M. Amer
Benha Higher Institute of Technology,
Egypt
dr_ghada11@hotmail.com

Dr. Kasim M. Al-Aubidy
Philadelphia University,
Jordan
kma@philadelphia.edu.jo

ABSTRACT

Premature infant incubator system is a vital and critical area because it deals with premature infant or illness baby. It is essential to detect any abnormal conditions occur in the premature infant incubator system as soon as possible. Temperature, humidity, and oxygen concentration are the main parameters must be control in the premature infant incubator system. In this paper novel technique by using Artificial Neural Network ANN is used in order to simulate the premature infant incubator control system by implementing the back propagation method. Sensors are used to indicate temperature, humidity, and oxygen concentration of the incubator internal environment. Sensors output are entering to the ANN, which identify the corresponding case and decide the suitable reaction upon previous training. The proposed ANN premature incubator control system in all conditions that can occur in the premature infant incubator environment proved right decision.

KEYWORDS: Premature infant, Incubator, Computer control, ANN, Neural control.

1. INTRODUCTION:

The incubator is considered as an air conditioned room with special specification which we can control it with respect to the condition of baby incubator which case the air flowing to upper area so dismiss the CO₂ from the special upper windows. Incubators are designed to provide an optimal environment for newborn babies with growth problems (premature baby) or with illness problems. The incubator is isolated area environment with no dust, bacteria, and has the ability to control temperature, humidity, and oxygen to remain them in acceptable levels such as (36°C-38°C) for temperature, (70%-75%) for humidity and (25%-60%) for oxygen concentration [1]. Newborn babies with growth problems usually have a net body area greater than normal babies from the same age. This in turn makes their heat loss greater than normal babies. Moreover, their net mass is less than the normal babies and makes them unable to keep their body temperature to the

required level. With regard to sick babies, they usually can't control their body temperature without an external aid. The newness put in the incubator about 28 days after his born and he has the clinical care in the incubator from special window in the incubator to have his food, recording his weight, take care of him, make the small operates and X-ray without move the baby from his place [2]. Several types of control system were used to control the incubator internal environment to keep the premature baby safe. Most of these controllers can deal with abnormal conditions[3], since they have no ability to learn.

This paper presents a new technique to control the internal environment of the premature infant incubator by using Artificial Neural Network (ANN). A neural network is a powerful data-modeling tool that is able to capture and represent complex input/output relationships. The motivation for the development of neural network technology stemmed from the desire to develop an artificial system that could perform "intelligent" tasks similar to those performed by the human brain. The true power and advantage of neural networks lies in their ability to represent both linear and non-linear relationships, and in their ability to learn these relationships directly from the data being modeled. Traditional linear models are simply inadequate when it comes to modeling data that contains non-linear characteristics.

2. INTERNAL ENVIRONMENT SPECIFICATIONS:

The incubator is provided with motor and fan that sucks the air through it. Then the air-pass on to a heating grid followed by a water evaporator to gain the required humidity. If it is necessary oxygen can be added. The modern incubators are fitted with safety standards, voice, and light alarm indicators of emergency. The three important parameters specify the internal environment of the baby incubator is temperature, humidity, and oxygen concentrations. So in this paper three sensors are used to convert these three quantities to electrical quantities, which will be the input to the proposed ANN control system.

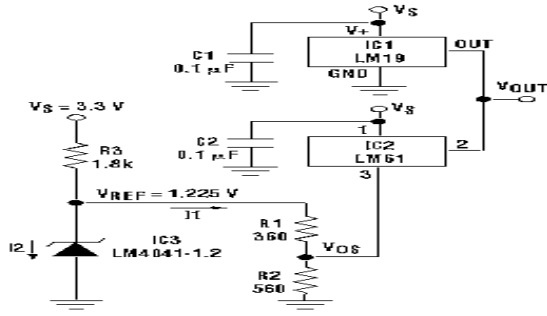

Fig. 1. The dual-slope temperature sensor circuit

3. SENSORS:

This section presents types of the three sensors that will be used in incubator for controlling temperature, humidity, and oxygen concentration. The output voltages of these sensors are used to feed the proposed Artificial Neural Network.

3.1 Temperature Sensor:

In this paper the frequency drift of XT-cut crystals is used, which have a parabolic curve with the center frequency typically specified at 25°C. The dual-slope temperature sensor circuit shows in Fig. 1 combines one negative-sloped and one positive-sloped temperature sensor to create a V-shaped output, which can be used to compensate for a dual-temperature-coefficient thermal response [4]. The transfer function of the LM19 (IC1) can be closely approximated at room temperature as a straight line with the equation:

$$V_{out19} = -(0.0117V/C^\circ)T + 1.87V \quad (1)$$

where T is temperature in °C. The transfer function of the LM61 (IC2) is a straight line with the equation:

$$V_{out61} = -(0.01 V/C^\circ) T + 0.6 V \quad (2)$$

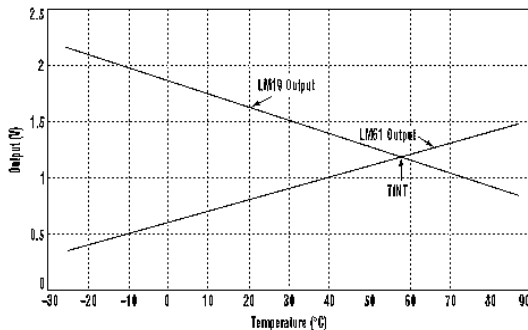

Fig. 2. The outputs of two individual

The two lines are plotted in Fig. 2, which shows that the temperature of intersection (T_{INT}) is 58.55°C. Since the LM19 and LM61 essentially do not sink current (less than 10 μ A), V_{OUT} will be equal to whichever device has the higher output voltage. These results are in a V-shaped output curve with a minimum at T_{INT} [4]. To use this circuit to compensate for a dual-temperature-coefficient, it is desirable to have the minimum of the V-shaped curve occur at the same temperature as the maximum of the thermal response being compensated. To reduce T_{INT} to the desired temperature (25°C), an additional offset voltage V_{OS} is added to the LM61 via the R_1 - R_2 voltage divider, giving a new equation for the LM61 output:

$$V_{out61} = (0.01 V/C^\circ) + 0.6 V + V_{os} \quad (3)$$

where V_{OS} is calculated by setting Eqs. (1) and (3) equal to each other and substituting the desired T_{INT} for T. [4] For a T_{INT} of 25°C, the value of V_{OS} is 0.728 V. The values of R_1 and R_2 must therefore be selected such that;

$$\frac{R_2}{R_1 + R_2} = \frac{V_{os}}{V_{ref}} = 0.594 \quad (4)$$

The value of I_1 , shown in Fig. 1, is determined by R_1 and R_2 , and it should be set to significantly more than the quiescent current through the LM61 (125 μ A max) in order to reduce errors caused by this quiescent current passing through R_2 . Choosing I_1 to be 10 times greater than the quiescent current gives the condition:

$$\frac{1.255 V}{R_1 + R_2} \geq 1.25 mA \quad (5)$$

Solving Eqs. (4) and (5) gives $R_1 = 398 \Omega$ and $R_2 = 582 \Omega$. The circuit in Fig. 1 uses the standard resistor values of 360 Ω and 560 Ω to satisfy Eq. (5) and gives a ratio of 0.636, very close to that of Eq. (4) Finally, R_3 is selected so that I_2 shown in Fig. 1, is within the operating range of the LM4041 voltage reference. The air temperature adjustment rang in incubator is 20:40°C, but T_{INT} is 58.55°C so sensor then LM19 will be sufficient to our study.

3.2 Humidity Sensor:

Humidity transmitters provide a high accuracy from 4 to 20 mA humidity measurements. [5] The output of all absorption based humidity sensors (capacitive, bulk resistive, conductive film, etc.) are affected by both temperature and %RH. Because of this, temperature compensation is used in applications, which call for either higher accuracy or wider operating temperature ranges [5]. When temperature compensating a humidity sensor, it is best to make the temperature measurement as close as possible to the humidity sensor's active area,

i.e. within the same moisture microenvironment. The RHIC sensor linear voltage output is a function of V_{supply} , % RH, and temperature. The output is “ratio metric” i.e. as the supply voltage rises; the output voltage rises in the same proportion. A surface plot of the sensor behavior for temperatures between 0°C and 85°C is shown in Fig. 3. This surface plot is well approximated by a combination of two equations:

1. A sensor specific equation can be obtained from an RH the printout equation assumes $V_{\text{supply}} = 5\text{VDC}$ and is included or available as an option on every sensor.

$$V_{\text{out}} = V_{\text{supply}} (0.0062(\%RH) + 0.16) \quad (6)$$

2. A sensor independent equation, which corrects the %RH reading (from the best fit line equation) for temperature, T:

$$\text{True RH} = (\%RH) / (1.0546 - 0.00216 T); T = C^\circ \quad (7)$$

OR

$$\text{True RH} = (\%RH) / (1.0930 - 0.0012 T); T = F^\circ \quad (8)$$

The equations above match the typical surface plot (best fit line at 25°C) or the actual surface plot (sensor specific equation at 25°C) to within the following tolerances:

$$\pm 1\% \text{ for } T > 20^\circ C \quad (9)$$

$$\pm 2\% \text{ for } 10^\circ C < T < 20^\circ C \quad (10)$$

$$\pm 5\% \text{ for } T < 10^\circ C \quad (11)$$

The range of temperature in incubator should be between (27-40)°C then, error produced according to relation number as in Eq. (9), So error = ±1% (very small) then we operate with Eq. (6) directly.

3.3 Optical Transparent Oxygen Sensor:

Incorrect procedure when using oxygen can have serious consequences for the patient, including blindness, brain damage, or even death. The indicator flashes for an oxygen addition of 2 liters minute (2l/min.). The type of oxygen addition, the concentration and the duration of treatment must only be determined by instruction from qualified medical personnel. Oxygen flow meters cannot be used for determining the O₂ concentration. For oxygen therapy, the concentration must be continuously monitored, without fail, with a calibrated oxygen-measuring unit [6]. Even very small amounts of flammable material, such as alcohol, oil and disinfecting agents, ignite more easily with oxygen and burn rapidly in oxygen enriched atmosphere. The use of oxygen increases the danger of fire. Oxygen can be added to the air supplied to the premature baby in the incubator via a side connector. Fresh air and oxygen supply are mutually adapted in the regulator block; oxygen addition from 2l/min. causes the "O₂ flow" indicator to flash. Oxygen concentrations in the canopy of maximum 50 – 60% can thereby be achieved. A flow meter is used for dosage (optional).

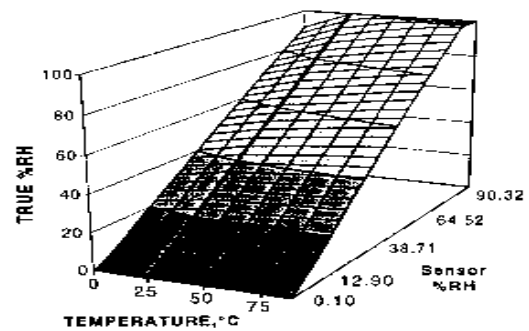

Fig. 3. Relative humidity sensor reading versus temperature and true relative humidity.

The oxygen concentration can be determined in gaseous media, such as ventilating air, under oxygen canopies, inside incubator, etc., with the O₂ monitor. The concentration is measured with an electro-chemical sensor and displayed in percent by volume on the monitor. The unit has mutually independently adjustable upper and lower alarm thresholds with acoustic and optical alarm. Battery or storage battery operation is possible. In this study, a thinner and optical transparent oxygen sensor with bending flexibility was constructed using an ITO (Indium Tin Oxide) electrode and some functional polymer, and evaluated the characteristics of the device, such as optical, electrochemical performances and mechanical property [6]. Behavior of the oxygen sensor was evaluated by a cyclic voltammeter method using a computer controlled electrochemical analysis apparatus with a function generator Fig. 4. In order to look for a reduction potential of the sensor device, the applied potential to the ITO electrode is swept against the reference electrode from 0 to 1000 mV with a scan rate of 5 mV/sec in a batch measurement cell [6]. As the results of the spectrophotometer analysis (wavelength: 200-1100 nm), the optical absorbance at the sensitive area was also verified with being lower than 0.5 absorbance at the human visible wavelength from 400 to 700, which is consistent with the absorbencies of its components. The cyclic voltammogram of the ITO electrode is illustrated in Fig.5. As the current-potential curve with the scan rate of 5mV/sec at the figure indicates, the reduction current increases by sweeping the applied potential and the reduction current peaked in the neighborhood of the reduction potential of -900 mV. No degradation of the electrode and the change of the sensor performance were observed during and after the repeat potential sweeping. As Fig. 6 indicates, the current output of the transparent device is linearly related to the concentration of dissolved oxygen over a range of 0.05 – 8.52 mg/l, with a correlation coefficient of 0.999 deduced by regression analysis, as shown by the equation [6];

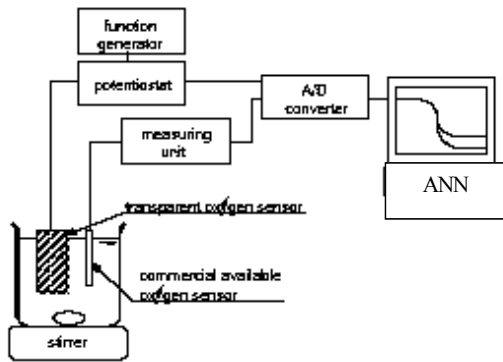

Fig. 4. Schematic diagram of the cyclic voltammeter of the transparent electrode.

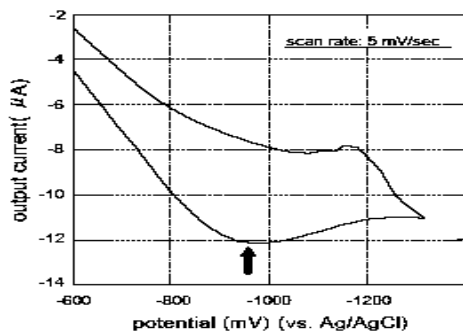

Fig. 5 Cyclic voltammogram of the ITO electrode (Sweep range: 0-1000 mV, scan rate: 5 mV/sec).

$$S_{out}(\mu A) = 0.076 + 0.444 [\text{dissolved oxygen (mg/l)}] \quad (12)$$

where S_{out} is the output of the sensor. The reproducibility of the transparent oxygen sensor was evaluated in test solutions. Sensor performance is reproducible over multiple measurements, showing a coefficient of variation of 2.46 % ($n = 20$). The optical transparent oxygen sensor is constructed with the ITO working electrode placed into between the non-permeable membrane and the gas-permeable membrane coated with Ag/AgCl electrode. The sensor device has flexible structure and good optical transparency the visible wavelength. The sensor[6] is used for measuring dissolved oxygen from 0.05-8.52 mg/l with good reproducibility (C.V.=2.46 %).

4. THE ANN CONTROLLER:

This section presents the application of ANN's for the premature incubator control system. The capability of premature incubator control system based on ANN theory to keep the reach accuracy when subject to different conditions of temperature, humidity, and oxygen addition variation. Figure 7 shows the block diagram of hardware implementation of premature incubator control system based on artificial neural network.

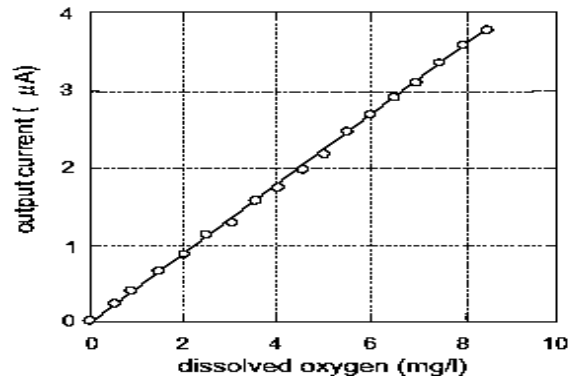

Fig. 6 Calibration plot of the transparent oxygen sensor for the dissolved oxygen measurement

The premature incubator control system works in the following sequence;

- 1- The voltage and current signals are taken from the sensors inside the premature incubator to get temperature, humidity, and oxygen concentration.
- 2- These values of voltage and current samples are indication of temperature degree, humidity percentage and oxygen concentration that will be input to ANN's which control premature incubator system.
- 3- ANN's outputs are indication of condition (as high-low temperature, large-lower percentage of humidity, high-low concentration of oxygen and other condition).
- 4- The forms of alarms are light, and other forms.

The signals output from the ANN's enter to different types of supervisory such as remote end (pager) or nurse room. The signals output from the ANN's may enter to feed back system to control temperature degree, humidity percentage and oxygen concentration in the form of (open oxygen valve, close heater, increase-decrease speed of air on water tank).

4.1 The ANN Structure:

This study proposes an ANN approach in order to simulate premature incubator control system by implementing the back-propagation method. The proposed ANN premature incubator control system should discriminate between any condition that occur in the incubator, giving alarms or lights for the situations described. In case of any condition occur .it should be mentioned that the input variables have to be normalized in order to reach the ANN input level from 0 to 2. In the case of premature incubator there are different conditions that required when controlling the temperature that occur at any change of temperature value in the incubator as shown in Table 1. There are different conditions that required when controlling the humidity percentage in the surrounding air of the canopy; Table 2 shows the different conditions that occur in the incubator and the humidity percentage.

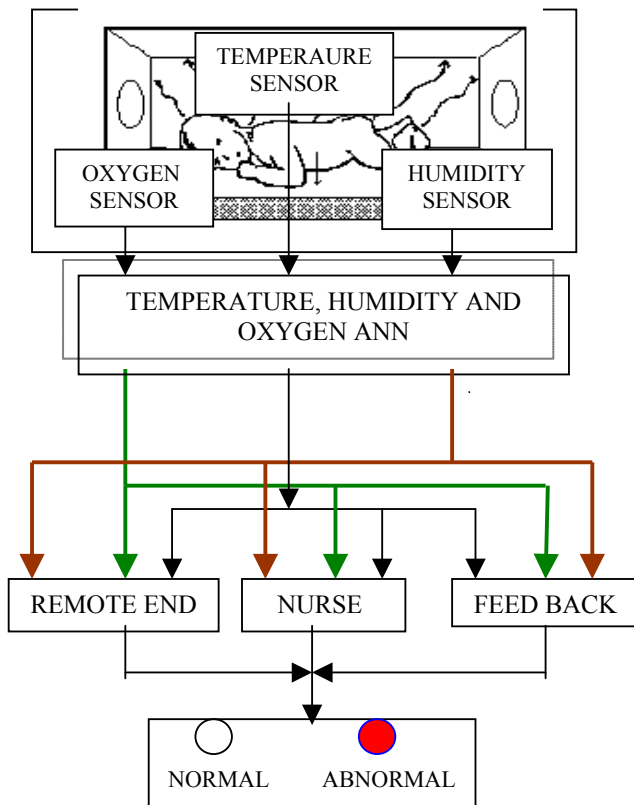

Fig. 7. Block diagram of ANN of premature incubator control system

Table 1 The conditions occur in the premature incubator

4.2 The ANN Architecture:

For the premature incubator control system ANN with 12 neurons organized in three layers, one input layer, one hidden layer, and one output layer is used. The number of neurons in the input and hidden layers are decided empirically. This process involved experimentation with various network configurations. The three inputs are defined previously in section 4-1. The transfer function used for the perceptrons is logistic sigmoid.

Table 2 The conditions occur in the premature incubator.

% of Humidity	Condition
From 0 to 30	Impossible
Greater than 30 to 58	Decrease the speed of air that pass over water tank

Greater than 58 to 64.5	Near Acceptable
Greater than 64.5 to 84.5	Normal
Greater than 84.5 to 94	Near Acceptable
Greater than 94 to 100	Increase the speed of air that pass over water tank

4.3 The ANN Training Procedures:

The training patterns should contain the necessary information to generalize the problem. This would enable the network to grasp and absorb the essence of the problem. For the purpose of the training premature incubator control system, shown in Fig 7 and described in section 4-1. The training patterns should contain the necessary information to generalize the problem. This would enable the network to grasp and absorb the essence of the problem. For the purpose of the training premature incubator control system, shown in Fig 7 and described in section 4-1.

Table 3: Different conditions of oxygen concentration occur in the premature incubator

% of Oxygen concentration	Condition
From 1 to 15	Emergency and call physical operator
Greater than 15 to 25	Open O ₂ valve
Greater than 25 to 60	Acceptable level according to premature condition
Greater than 60 to 70	Tight O ₂ valve and open outlet fan

Temp. C°	Condition
From 20 to 27	Emergency call physical operator
From 27 to 35	Open heater
From 35 to 37	Near acceptable
From 37 to 38.7	Acceptable
From 38.7 to 39.4	Near acceptable
From 39.4 to 41	Emergency call physical operator
Greater than 41 to 84	Close O ₂ valve and open outlet fan

Training patterns are generated by simulating all conditions of temperature, humidity, and oxygen concentration that may occur in the incubator. The data for training are obtained from the three sensors. The Neural Network Toolbox from the Matlab™ [7] is used to create the ANN diagram, train it, and obtain the weights and bias as out put. The initial weights as well as the initial bias employed random values between [0-1]. Training is stopped when the mean squared error

between the actual outputs and the desired outputs generated for test patterns stopped improving. A total number of 373 vectors defined in Tables 1, 2, and 3 are used to train the suggested ANN [8]. The learning factor, which controls the rate of convergence and stability, is chosen to be 0.01 in the beginning and is gradually reduced to be 0.001. Momentum factor, which is normally added to speed up the training and to avoid the local minimal, is kept at 0.95. The total number of epochs required to reach the global error of 0.01 is about 2120 as shown in Fig 8.

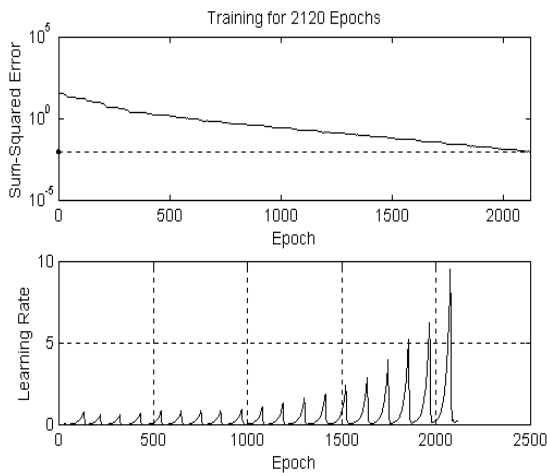

Fig 8. Sum-squared error and learning rate during learning process.

4.4 The ANN Testing:

In order to prove the effectiveness of the condition that occurred in the premature incubator by using the proposed ANN premature incubator control system, a number of conditions were tested. The proposed ANN is tested with a set of different conditions of temperature, humidity, and oxygen concentration. The output of the proposed ANN proves the efficiency of the proposed ANN premature incubator control system. Table 4 shows some of input temperature and output of the network to show the percentage of error that obtained from this network. From Table 4 it can be observed that the output of ANN % error is between $1.6e^{-2}$ and $4.6e^{-2}$. To test the effectiveness of the proposed ANN premature incubator control system when the input is humidity. The proposed ANN is tested with a set of different condition of humidity, and obtained the output of the proposed ANN. Table 5 shows some of input humidity and % error of the proposed ANN. It can be observed from Table 5 that the % error of the proposed ANN in controlling humidity is between 0.1 and 0.12. To check the effectiveness of the proposed ANN premature incubator control system when the input is oxygen concentration, numbers of oxygen concentration

conditions are tested as presented in Table 6. It is noticed that the % error in oxygen concentration controlled by the ANN is between 0.12 and 1.3. As it is clear from Tables 4, 5, and 6 it can be concluded that the % error of the suggested control system are very small values and the accuracy of such control is in agreement with the standard values [9-10].

Table 4: The temperature Error of the ANN.

Input to ANN	% Error of ANN	Input to ANN	% Error of ANN	Input to ANN	% Error of ANN
20.1	$2.786e^{-2}$	34.95	$6.867e^{-3}$	39.35	$4.320e^{-3}$
20.2	$2.772e^{-2}$	35.07	$6.843e^{-3}$	39.42	$4.313e^{-3}$
20.3	$2.709e^{-2}$	35.14	$6.830e^{-3}$	39.49	$4.305e^{-3}$
20.4	$2.696e^{-2}$	35.21	$6.532e^{-3}$	39.56	$4.297e^{-3}$
20.5	$2.683e^{-2}$	35.28	$6.519e^{-3}$	39.63	$4.290e^{-3}$
20.6	$2.621e^{-2}$	35.35	$6.506e^{-3}$	39.7	$4.282e^{-3}$
20.7	$2.609e^{-2}$	35.42	$6.494e^{-3}$	39.77	$4.275e^{-3}$
20.8	$2.596e^{-2}$	35.49	$6.481e^{-3}$	39.84	$4.267e^{-3}$
20.9	$2.584e^{-2}$	35.56	$6.468e^{-3}$	39.91	$4.009e^{-3}$
21.1	$2.512e^{-2}$	35.63	$6.455e^{-3}$	39.98	$4.002e^{-3}$

Table 5: Input and output humidity from the ANN.

Input Humidity	% Error of ANN	Input Humidity	% Error of ANN
35.0000	0.1110	58.0009	0.1133
40.0000	0.1115	59.0101	0.1134
44.5000	0.1120	60.9559	0.1335
50.5252	0.1126	61.0001	0.1134
51.0000	0.1127	62.0000	0.1135
53.5355	0.1130	65.5502	0.1137
55.6666	0.1131	64.0021	0.1136
56.9000	0.1193	65.5000	0.1137
57.0900	0.1131	68.0010	0.1138
57.9595	0.1133	70.0000	0.1138

Table 6: The input and output oxygen concentration of the ANN.

Target	% Error of ANN	Target	% Error of ANN
1	1.26	4.5	0.389
1.5	0.887	82	0.1776
2	0.7	83	0.1771
2.5	0.588	83.5	0.1769
3	0.513	84	0.1767

5- CONCLUSIONS

Novel technique of premature incubator infant control system is proposed, justified, and implemented. This technique depends on computing the voltages and currents outputs sensors and feeding Artificial Neural Network. From this study the following conclusions are investigated:

- 1- Three important parameters are found to simulate the control system inside the incubator; these parameters are temperature, humidity, and oxygen concentration.
- 2- Three different types of sensors are modified and used to sense the three parameters in the chosen incubator (AMELETTE model).
- 3- The proposed Artificial Neural Network (ANN) based to control the premature infant incubator system is tested with a set of different cases including very extreme cases. The % errors of this system is ranged between $1.6e^{-2}$ to $4.6e^{-2}$ in controlling the temperature, between 0.1 to 0.12 in controlling the humidity and is between 0.12 to 1.3 in controlling the oxygen concentration.
- 4- The performance average, for the suggested temperature control based on the Artificial Neural Network (ANN) is about 99.98%. This value for humidity is about 99.987% and for oxygen concentration 99.988 %.

REFERENCES

- [1]. JHON G. WEBSTER Medical instrumentation application and design.
- [2]. Gray PH, Leady V Cot-nursing versus incubator care for prater infants
- [3]. Aileen Wu, Yale Maguire and Parsing Lounge ” Prematurely Challenged”
- [4]. [http:// www.RS.com](http://www.RS.com)
- [5]. [http:// www.honeywell.com](http://www.honeywell.com)
- [6]. The Measurement of the Oxygenation Status of the Newborn Infant a dissertation submitted to the Swiss federal institute of technology Zurich Martin Peter Wolf Dipl. El.-Ing. ETH Prof. Dr. P. Niederer, examiner Prof. Dr. H. -U. Bucher, co-examiner 1996.
- [7]. MATLAB help.
- [8]. W. P. D. 1998 “neural computing theory and practice.”
- [9]. [http://www. Epsicot_Infant.com](http://www.Epsicot_Infant.com) ‘Epsicot Infant Incubator Technical Specifications ‘.
- [10]. The Van Hemel Incubator Website; <http://www.clinicalresearch.nl/incubator/INFO.HTM>

Biography

Dr Ghada M. Amer was born in Manama, Bahrain, in 1972. She received the degree of Bsc. in electrical engineering from Benha Higher Institute of Technology in 1995, the master degree in electrical power engineering from faculty of engineering, Cairo university in 1999. And PhD. degree in electrical power engineering from faculty of engineering, Cairo university in 2002. She works lecture in electrical department in Benha Higher Institute of Technology. Her present interests are the protection system, effect EMF of high voltage transmission lines, and biomedical engineer.

Kasim Al-Aubidy received his BSc and MSc degrees in control and computer engineering from the University of Technology, Iraq in 1979 and 1982, respectively, and the PhD degree in real-time computing from the University of Liverpool, England in 1989. He is currently an associative professor in the Department of Computer Engineering at Philadelphia University, Jordan. His research interests include fuzzy logic, neural networks, genetic algorithm and their real-time applications. He is the winner of Philadelphia Award for the best researcher in 2000. He is also a member of the editorial board of the Asian Journal of Information Technology. He has coauthored 3 books and published 48 papers on topics related to computer applications.